

LABORATORY BIOSAFETY MANUAL  
FOURTH EDITION  
AND  
ASSOCIATED MONOGRAPHS

# LABORATORY BIOSAFETY MANUAL FOURTH EDITION



LABORATORY BIOSAFETY MANUAL  
FOURTH EDITION  
AND  
ASSOCIATED MONOGRAPHS

# LABORATORY BIOSAFETY MANUAL FOURTH EDITION

Laboratory biosafety manual, fourth edition

(Laboratory biosafety manual, fourth edition and associated monographs)

ISBN 978-92-4-001131-1 (electronic version)

ISBN 978-92-4-001132-8 (print version)

© World Health Organization 2020

Some rights reserved. This work is available under the Creative Commons Attribution-NonCommercial-ShareAlike 3.0 IGO licence (CC BY-NC-SA 3.0 IGO; <https://creativecommons.org/licenses/by-nc-sa/3.0/igo>).

Under the terms of this licence, you may copy, redistribute and adapt the work for non-commercial purposes, provided the work is appropriately cited, as indicated below. In any use of this work, there should be no suggestion that WHO endorses any specific organization, products or services. The use of the WHO logo is not permitted. If you adapt the work, then you must license your work under the same or equivalent Creative Commons licence. If you create a translation of this work, you should add the following disclaimer along with the suggested citation: "This translation was not created by the World Health Organization (WHO). WHO is not responsible for the content or accuracy of this translation. The original English edition shall be the binding and authentic edition".

Any mediation relating to disputes arising under the licence shall be conducted in accordance with the mediation rules of the World Intellectual Property Organization (<http://www.wipo.int/amc/en/mediation/rules/>).

**Suggested citation.** Laboratory biosafety manual, fourth edition. Geneva: World Health Organization; 2020 (Laboratory biosafety manual, fourth edition and associated monographs). Licence: [CC BY-NC-SA 3.0 IGO](https://creativecommons.org/licenses/by-nc-sa/3.0/igo).

**Cataloguing-in-Publication (CIP) data.** CIP data are available at <http://apps.who.int/iris>.

**Sales, rights and licensing.** To purchase WHO publications, see <http://apps.who.int/bookorders>. To submit requests for commercial use and queries on rights and licensing, see <http://www.who.int/about/licensing>.

**Third-party materials.** If you wish to reuse material from this work that is attributed to a third party, such as tables, figures or images, it is your responsibility to determine whether permission is needed for that reuse and to obtain permission from the copyright holder. The risk of claims resulting from infringement of any third-party-owned component in the work rests solely with the user.

**General disclaimers.** The designations employed and the presentation of the material in this publication do not imply the expression of any opinion whatsoever on the part of WHO concerning the legal status of any country, territory, city or area or of its authorities, or concerning the delimitation of its frontiers or boundaries. Dotted and dashed lines on maps represent approximate border lines for which there may not yet be full agreement.

The mention of specific companies or of certain manufacturers' products does not imply that they are endorsed or recommended by WHO in preference to others of a similar nature that are not mentioned. Errors and omissions excepted, the names of proprietary products are distinguished by initial capital letters.

All reasonable precautions have been taken by WHO to verify the information contained in this publication. However, the published material is being distributed without warranty of any kind, either expressed or implied. The responsibility for the interpretation and use of the material lies with the reader. In no event shall WHO be liable for damages arising from its use.

Design and layout by Paul Bloxham

# Contents

<b>Acknowledgements</b>	<b>vi</b>
<b>Glossary of terms</b>	<b>x</b>
<b>Foreword</b>	<b>xvii</b>
<b>SECTION 1 Introduction</b>	<b>1</b>
1.1 Intended scope	2
1.2 How to use the <i>Laboratory biosafety manual</i>	3
<b>SECTION 2 Risk assessment</b>	<b>5</b>
2.1 Gather information	9
2.2 Evaluate the risks	11
2.3 Develop a risk control strategy	17
2.4 Select and implement risk control measures	18
2.5 Review risks and risk control measures	25
<b>SECTION 3 Core requirements</b>	<b>27</b>
3.1 Good microbiological practice and procedure	27
3.2 Personnel competence and training	31
3.3 Facility design	31
3.4 Specimen receipt and storage	34
3.5 Decontamination and waste management	35
3.6 Personal protective equipment	41
3.7 Laboratory equipment	43
3.8 Emergency/incident response	45
3.9 Occupational health	47

<b>SECTION 4 Heightened control measures</b>	<b>49</b>
4.1 Operational working practices and procedures	49
4.2 Personnel competence and training	50
4.3 Facility design	50
4.4 Specimen receipt and storage	51
4.5 Decontamination and waste management	51
4.6 Personal protective equipment	51
4.7 Laboratory equipment	54
4.8 Emergency/incident response	55
4.9 Occupational health	55
<b>SECTION 5 Maximum containment measures</b>	<b>59</b>
5.1 Operational working practices and procedures	60
5.2 Personnel competence and training	60
5.3 Facility design	60
5.4 Specimen receipt and storage	63
5.5 Decontamination and waste management	63
5.6 Personal protective equipment	63
5.7 Laboratory equipment	64
5.8 Emergency/incident response	64
5.9 Occupational health	64
<b>SECTION 6 Transfer and transportation</b>	<b>65</b>
6.1 Transfer within the laboratory	65
6.2 Transfer within a building	66
6.3 Transfer between buildings on the same site	66

6.4 Off-site transport of infectious substances	68
<b>SECTION 7 Biosafety programme management</b>	<b>77</b>
7.1 Biosafety culture	78
7.2 Biosafety policy	78
7.3 Assigned roles and responsibilities	79
7.4 Biosafety manual	80
7.5 Biosafety and biosecurity risk assessment	80
7.6 Supporting programmes and plans	80
7.7 Reports and reviews	81
<b>SECTION 8 Laboratory biosecurity</b>	<b>83</b>
8.1 Biosecurity risk assessment	84
8.2 Inventory control	85
8.3 Information control	85
8.4 Personnel control	86
8.5 Physical security control	86
8.6 Transport control	87
8.7 Emergency/incident response	87
8.8 Emerging biological risks	88
8.9 Dual use research of concern	89
<b>SECTION 9 National/international biosafety oversight</b>	<b>91</b>
<b>References</b>	<b>95</b>
<b>Further information</b>	<b>100</b>

# Acknowledgements

## Principal coordinator

Dr Kazunobu Kojima, World Health Organization, Switzerland

## Scientific contributors

Mr Allan Bennett, Public Health England (WHO Collaborating Centre for Applied Biosafety and Training), United Kingdom of Great Britain and Northern Ireland

Prof. Stuart Blacksell, University of Oxford/Mahidol-Oxford Tropical Medicine Research Unit, Thailand

Ms Marianne Heisz, Public Health Agency of Canada (WHO Collaborating Centre for Biosafety and Biosecurity), Canada

Dr Catherine Makison Booth, Health and Safety Executive, United Kingdom of Great Britain and Northern Ireland

Ms Michelle McKinney, Centers for Disease Control and Prevention (WHO Collaborating Centre for Biosafety and Biosecurity), and National Institutes of Health, United States of America

Dr Kathrin Summermatter, Institute for Infectious Diseases, University of Bern, Switzerland

## Project management

Ms Lisa Stevens, World Health Organization, France

Ms Rica Zinsky, World Health Organization, Switzerland

## Reviewers - individuals

Dr Amadou Alpha Sall, Institut Pasteur de Dakar, Senegal

Dr William Ampofo, Noguchi Memorial Institute for Medical Research, University of Ghana, Ghana

Dr Åsa Szekely Björndal, Public Health Agency of Sweden, Sweden

Dr Christina Carlson, World Health Organization, Switzerland and Centers for Disease Control and Prevention (WHO Collaborating Centre for Biosafety and Biosecurity), United States of America



Dr Mike Catton, Victorian Infectious Diseases Reference Laboratory, Peter Doherty Institute for Infection and Immunity, Australia

Dr Sébastien Bruno Francois Cognat, World Health Organization, France

Dr Clarissa Damaso, Federal University of Rio de Janeiro, Brazil

Dr Francois Diaz, World Organisation for Animal Health, France

Ms Maureen Ellis, International Federation of Biosafety Associations, Canada

Dr David Franz, United States of America

Dr Isabel Hunger-Glaser, Swiss Expert Committee for Biosafety, Switzerland

Dr Kevin Karem, Centers for Disease Control and Prevention (WHO Collaborating Centre for Biosafety and Biosecurity), United States of America

Dr Paul Meechan, Centers for Disease Control and Prevention (WHO Collaborating Centre for Biosafety and Biosecurity), United States of America

Dr Masayuki Saijo, National Institute of Infectious Diseases, Japan

Dr Rosemary Sang, Kenya Medical Research Institute, Kenya

Dr Christina Scheel, Centers for Disease Control and Prevention (WHO Collaborating Centre for Biosafety and Biosecurity), United States of America

Mr Andrew Thompson, University of Oxford, United Kingdom of Great Britain and Northern Ireland

### **Reviewers – organizations/associations/societies/offices**

#### **Internal – World Health Organization**

Regional Office for Africa – Mamoudou Harouna Djingarey, Yahaya Ali Ahmed, Tieble Traore, Sheick Oumar Coulibaly, Belinda Louise Herring

Regional Office for the Americas – Jean-Marc Gabastou

Regional Office for South-East Asia – Aparna Singh Shah, Francis Yesurajan Inbanathan

Regional Office for Europe – Joanna Zwetyenga, Caroline Sarah Brown, Eugene Victor Saxentoff

Regional Office for the Eastern Mediterranean – Frank Konings, Amal Barakat, Amany Ghoniem, Humayun Asghar together with Tarek Al-Sanoury, Heba Abdulridha, Rhizlane Selka

Regional Office for the Western Pacific – Varja Grabovac, Orla Condell, Pakapak Ketmayoon, Karen Nahapetyan

WHO Antimicrobial Resistance – Carmem Lucia Pessoa da Silva

WHO Emergency Preparedness Division – Jaouad Mahjour

WHO Emerging and Dangerous Pathogens Laboratory Network – Pierre Formenty

WHO Food safety, Zoonosis and Foodborne Disease – Jorge Raul Matheu Alvarez, Amina Benyahia Chaieb, Kazuaki Miyagishima

WHO Global Outbreak Alert and Response Network – Patrick Anthony Drury

WHO Global Infectious Hazards Preparedness Department – Sylvie Briand, Tim Nguyen, Matthew Lim

WHO Global Influenza Programme – Magdi Samaan, Wenqing Zhang, Terry Gail Besselaar, Sandra Jackson

WHO Global Malaria Programme – Andrea Bosman, Jane A. Cunningham

WHO Global Tuberculosis Programme – Christopher Gilpin, Karin Weyer

WHO Health Systems and Innovation – Ivana Knezevic, Tiequn Zhou, Hye-na Kang, Francis Gabriel Moussy

WHO HIV/AIDS – Meg Doherty, Lara Vojnov, Silvia Bertagnolio

WHO Immunization, Vaccines and Biologicals – Mick Mulders, Fatima Serhan, Deepa Sharma, Varja Grabovac,

WHO Laboratory Networks – Mark Perkins, Karin von Eije, Maria van Kerkhove

WHO Polio Eradication – Daphne Moffett, Nicoletta Claudia Previsani, Ousmane (Madiagne) Diop, Harpal Singh

WHO Public Health Laboratory Strengthening – Virginie Dolmazon, Céline Marie Joséphine Barnadas, José Guerra, Christopher John Oxenford, Evelyne Chaignat Wyssen, Lisa Louise Carter

WHO Regulation and Prequalification – Irena Prat, Mark Lanigan, Anita Sands

WHO R&D Blueprint – Vaseeharan Sathiyamoorthy

**External**

Afghanistan Biosafety Association, African Society of Laboratory Medicine, American Biological Safety Association, American Society of Microbiology, Argentina Biosafety Committee, Association for Biosafety and Biosecurity International, Association for Biosecurity in Côte d'Ivoire, Bangladesh Biosafety & Biosecurity Association, Biorisk Management Association of Kenya, Biosafety Association for Central Asia and the Caucasus, Caribbean Public Health Agency, Centre on Global Health Security - Chatham House, European Union, European Centre for Disease Prevention and Control, European Society of Clinical Microbiology and Infectious Diseases, Food and Agriculture Organization of the United Nations, Georgian Biosafety Association, Action Package Prevent 3 - Global Health Security Agenda, Hellenic Society of Biosafety, Indian Council of Medical Research, Instituto de Diagnóstico y Referencia Epidemiológicos (WHO Collaborating Center on Laboratory Biosafety), International Atomic Energy Agency, International Experts Groups of Biosafety and Biosecurity Regulators, International Federation of Biosafety Associations, International Society for Infectious Diseases, International Union of Microbiological Societies, Latin America Association for Microbiology, Malaysia Biosafety and Biosecurity Association, Manipal Academy of Higher Education (Institution of Eminence Deemed to be University), Mexican Biosafety Association, Moroccan Biosafety Association, National Institutes of Health, Netherlands Commission on Genetic Modification, Netherlands National Institute for Public Health and the Environment, Pakistan Biological Safety Association, Portuguese Laboratory Biosafety Network, Spanish Association for Biosafety, Swiss Biosafety Network, US Department of Health & Human Services, United States Centers for Disease Control and Prevention (WHO Collaborating Centre for Biosafety and Biosecurity) - Division of Select Agents and Toxins, United States Centers for Disease Control and Prevention (WHO Collaborating Centre for Biosafety and Biosecurity) - Center for Global Health, Laboratory Science, World Organisation for Animal Health

**Technical editing**

Ms Fiona Curlet

**Financial support**

Development and publication of this document have been made possible with financial support from the Global Partnership Program, Global Affairs Canada, the Biosecurity Engagement Program, United States Department of State and the Defense Threat Reduction Agency, US Department of Defense.

## Glossary of terms

**Acceptable risk:** The risk that is considered acceptable and allows work to proceed bearing in mind the expected benefit of the planned activities.

**Accident:** An inadvertent occurrence that results in actual harm such as infection, illness, injury in humans or contamination of the environment.

**Aerosol:** Liquid or solid particles suspended in air and of a size that may allow inhalation into the lower respiratory tract (usually less than 10 micrometres in diameter).

**Aerosol/airborne transmission:** The spread of infection caused by the inhalation of aerosols.

**Aerosol-generating procedure:** Any procedure that intentionally or inadvertently results in the creation of liquid or solid particles, which become suspended in the air (aerosols).

**Aseptic techniques:** Conditions and procedural measures designed to effectively prevent contamination.

**Biological agent:** A microorganism, virus, biological toxin, particle or otherwise infectious material, either naturally occurring or genetically modified, which may have the potential to cause infection, allergy, toxicity or otherwise create a hazard to humans, animals, or plants.

**Biological safety cabinet (BSC):** An enclosed, ventilated working space designed to provide protection to the operator, the laboratory environment and/or the work materials for activities where there is an aerosol hazard. Containment is achieved by segregation of the work from the main area of the laboratory and/or through the use of controlled, directional airflow mechanisms. Exhaust air is passed through a high efficiency particulate air (HEPA) filter before recirculating into the laboratory or into the building's heating, ventilation and air conditioning system. There are different classes (I, II and III) of BSCs that provide different levels of containment.

**Biosafety:** Containment principles, technologies and practices that are implemented to prevent unintentional exposure to biological agents or their inadvertent release.

**Biosafety committee:** An institutional committee created to act as an independent review group for biosafety issues, reporting to senior management. The membership of the biosafety committee should reflect the different occupational areas of the organization as well as its scientific expertise.

**Biosafety officer:** An individual designated to oversee facility or organizational biosafety (and possibly biosecurity) programmes. The person fulfilling this function may also be termed biosafety professional, biosafety advisor, biosafety manager, biosafety coordinator, or biosafety management advisor.

**Biosafety programme management:** The development, implementation and oversight of biosafety at the organizational level using a variety of information that includes institutional policies, guidance documents for practices and procedures, planning documents (training, recruitment, emergency/incident response) and record keeping (personnel, inventories, incident management).

**Biosecurity:** Principles, technologies and practices that are implemented for the protection, control and accountability of biological materials and/or the equipment, skills and data related to their handling. Biosecurity aims to prevent their unauthorized access, loss, theft, misuse, diversion or release.

**Calibration:** Establishment of the relationship between the measurement provided by the instrument and the corresponding values of a known standard, allowing correction to improve accuracy. For example, laboratory equipment such as pipetting devices may need calibration periodically to ensure proper performance.

**Certification:** A third-party testimony based on a structured assessment and formal documentation confirming that a system, person or piece of equipment conforms to specified requirements, for example, to a certain standard.

**Code of practice (code of conduct, code of ethics):** Non-legislated guidelines for behavioural and practical standards that are voluntarily accepted as best practice and are thus followed by one or more organizations and/or individuals.

**Communicability:** Capability of a biological agent to be transmitted from one person or animal to another, either through direct or indirect transmission. This is often related to/represented by an epidemiological measurement called the basic reproduction number ( $R_0$ ) which is an average number of secondary infections generated by a single infected individual in a fully susceptible population.

**Consequence (of a laboratory incident):** The outcome of an incident (exposure to and/or release of a biological agent) of varying severity of harm, occurring in the course of laboratory operations. Consequences may include a laboratory-associated infection, other illness or physical injury, environmental contamination, or asymptomatic carriage of a biological agent.

**Containment:** The combination of physical design parameters and operational practices that protect personnel, the immediate work environment and the community from exposure to biological agents. The term "biocontainment" is also used in this context.

**Core requirements:** A set of minimum requirements defined in the fourth edition of the World Health Organization (WHO) *Laboratory biosafety manual* to describe a combination of risk control measures that are both the foundation for, and an integral part of, laboratory biosafety. These measures reflect international standards and best practice in biosafety that are necessary to work safely with biological agents, even where the associated risks are minimal.

**Decontamination:** Reduction of viable biological agents or other hazardous materials on a surface or object(s) to a pre-defined level by chemical and/or physical means.

**Disinfectants:** Agents capable of eliminating viable biological agents on surfaces or in liquid waste. These will have varying effectiveness depending on the properties of the chemical, its concentration, shelf life and contact time with the agent.

**Disinfection:** A process to eliminate viable biological agents from items or surfaces for further safe handling or use.

**Droplets:** A suspension of particles, normally defined as more than 10 micrometres in diameter, which tends to fall out of the air resulting in contamination of nearby surfaces.

**Dual use items:** Certain materials, information and technologies that are intended for benefit, but which might be misapplied to do harm.

**Emergency/incident response:** An outline of the behaviours, processes and procedures to be followed when handling sudden or unexpected situations, including exposure to or release of biological agents. The goal of an emergency/incident response is to prevent injuries or infections, reduce damage to equipment or the environment, and accelerate resumption of normal operations.

**Endemic disease:** A disease naturally occurring in a particular region or population.

**Engineering controls:** Risk control measures that are built into the design of a laboratory or laboratory equipment to contain the hazards. Biological safety cabinets (BSCs) and isolators are forms of engineering control in order to minimize the risk of exposure to and/or unintended release of biological agents.

**Exotic disease:** A disease not normally occurring in a particular region or area, often imported from another area. It can also be referred to as non-indigenous disease.

**Exposure:** An event during which an individual comes in contact with, or is in close proximity to, biological agents with the potential for infection or harm to occur. Routes of exposure can include inhalation, ingestion, percutaneous injury and absorption and are usually dependent upon the characteristics of the biological agent. However, some infection routes are specific to the laboratory environment and are not commonly seen in the general community.

**Good microbiological practice and procedure (GMPP):** A basic laboratory code of practice applicable to all types of laboratory activities with biological agents, including general behaviours and aseptic techniques that should always be observed in the laboratory. This code serves to protect laboratory personnel and the community from infection, prevent contamination of the environment, and provide protection for the work materials in use.

**Hazard:** An object or situation that has the potential to cause adverse effects when an organism, system or (sub)population is exposed to it. In the case of laboratory biosafety, the hazard is defined as biological agents which have the potential to cause adverse effects to personnel and/or humans, animals, and the wider community and environment. A hazard does not become a “risk” until the likelihood and consequences of that hazard causing harm are taken into account.

**Heightened control measures:** A set of risk control measures as described in the WHO *Laboratory biosafety manual* that may need to be applied in a laboratory facility because the outcome of a risk assessment indicates that the biological agents being handled and/or the activities to be performed with them are associated with a risk that cannot be brought below an acceptable risk with the core requirements only.

**Inactivation:** Removal of the activity of biological agents by destroying or inhibiting reproductive or enzyme activity.

**Incident:** An occurrence that has the potential to, or results in, the exposure of laboratory personnel to biological agents and/or their release into the environment that may or may not lead to actual harm.

**Infectious dose:** The amount of biological agent required to cause an infection in the host, measured in number of organisms. Often defined as the  $ID_{50}$ , the dose that will cause infection in 50% of those exposed.

**Infectious substances:** The term applied for the purposes of transport to any material, solid or liquid, which contains biological agents capable of causing infection in either humans, animals or both. Infectious substances can include patient specimens, biological cultures, medical or clinical wastes and/or biological products such as vaccines.

**Initial risk:** Risk associated with laboratory activities or procedures that are conducted in the absence of risk control measures.

**Laboratory-associated infection:** Any infection acquired or reasonably assumed as a result of exposure to a biological agent in the course of laboratory-related activities. A person-to-person transmission following the incident may result in linked secondary cases. Laboratory-associated infections are also known as laboratory-acquired infections.

**Likelihood (of a laboratory incident):** The probability of an incident (that is exposure to and/or a release of a biological agent) occurring in the course of laboratory work.

**Maximum containment measures:** A set of highly detailed and stringent risk control measures described in the fourth edition of the WHO *Laboratory biosafety manual* that are considered necessary during laboratory work where a risk assessment indicates that the activities to be performed pose very high risks to laboratory personnel, the wider community and/or the environment, and therefore an extremely high level of protection must be provided. These are especially needed for certain types of work with biological agents that may have catastrophic consequences if an exposure or release were to occur.

**One Health:** An approach to designing and implementing programmes, policies, legislation and research in which multiple sectors communicate and work together to achieve better public health outcomes. The areas of work in which a One Health approach is particularly relevant include food safety, the control of zoonoses, and combatting antibiotic resistance.

**Pathogen:** A biological agent capable of causing disease in humans, animals or plants.

**Personal protective equipment (PPE):** Equipment and/or clothing worn by personnel to provide a barrier against biological agents, thereby minimizing the likelihood of exposure. PPE includes, but is not limited to, laboratory coats, gowns, full-body suits, gloves, protective footwear, safety glasses, safety goggles, masks and respirators.

**Primary containment device (equipment):** A contained workspace designed to provide protection to its operator, the laboratory environment and/or the work materials for activities where there is an aerosol hazard. Protection is achieved by segregation of the work from the main area of the laboratory and/or through the use of controlled, directional airflow mechanisms. Primary containment devices include biological safety cabinets (BSCs), isolators, local exhaust ventilators and ventilated working spaces.

**Propagation:** The action of intentionally increasing or multiplying the number of biological agents.

**Prophylaxis:** Treatment given to prevent infection or to mitigate the severity of the disease if infection were to occur. It can be delivered before possible exposure or after exposure before the onset of infection.

**Redundancy:** Repetitions of systems or parts of a system to provide protection in the case of a primary system failure. For example, a series of high efficiency particulate air (HEPA) filters in case one or more fail when used to move laboratory air to the outside environment.

**Residual risk:** Risk that remains after carefully selected risk control measures have been applied. If residual risk is not acceptable, it may be necessary to apply additional risk control measures or to stop the laboratory activity.

**Risk:** A combination of the likelihood of an incident and the severity of the harm (consequences) if that incident were to occur.



**Risk assessment:** A systematic process of gathering information and evaluating the likelihood and consequences of exposure to or release of workplace hazard(s) and determining the appropriate risk control measures to reduce the risk to an acceptable risk.

**Risk communication:** An interactive and systematic process to exchange information and opinion on risk(s) that inclusively engages all relevant personnel of various categories as well as community leaders and officials where appropriate. Risk communication is an integral and ongoing part of the risk assessment, soliciting clear understanding of the risk assessment process and outcomes, aiming at proper implementation of risk control measures. Decisions on risk communication, including what, whom and how, should be part of an overall risk communication strategy.

**Risk control measure:** Use of a combination of tools, which include communication, assessment, training, and physical and operational controls, to reduce the risk of an incident/event to an acceptable risk. The risk assessment cycle will determine the strategy that should be used to control the risks and the specific types of risk control measures required to achieve this.

**Risk evaluation:** Part of risk assessment where the likelihood of exposure to a hazard is weighed against the potential severity of harm under a set of predefined circumstances, such as a specific laboratory procedure. The goal of a risk evaluation is to determine whether the assessed risk is acceptable, or whether further targeted risk control measures should be implemented to prevent or reduce the risks.

**Safety culture:** A set of values, beliefs and patterns of behaviour instilled and facilitated in an open and trusting atmosphere by individuals and organizations working together to support or enhance best practice for laboratory biosafety, irrespective of whether it is stipulated in applicable codes of practice and/or regulations.

**Sharps:** Any device or object that is a puncture or wound hazard because of its pointed ends or edges. In the laboratory, sharps can include needles, syringes with attached needles, blades, scalpels or broken glass.

**Standard operating procedures (SOPs):** A set of well-documented and validated stepwise instructions outlining how to perform laboratory practices and procedures in a safe, timely and reliable manner, in line with institutional policies, best practice and applicable national or international regulations.

**Sterile:** The state of having a complete absence of viable biological agents and spores.

**Sterilization:** A process that kills and/or removes all biological agents including spores.

**Transmission:** The transfer of biological agent(s) from objects to living things, or between living things, either directly or indirectly via aerosols, droplets, body fluids, vectors, food/water or other contaminated objects.

**Validation:** Systematic and documented confirmation that the specified requirements are adequate to ensure the intended outcome or results. For example, in order to prove a material is decontaminated, laboratory personnel must validate the robustness of the decontamination method by measurement of the remaining biological agents against the detection limit by chemical, physical or biological indicators.

**Verification:** Confirmation that a given item (product, process or system) satisfies the specified requirements. For example, verification that the performance of an autoclave meets the standards specified by the manufacturer should be performed periodically.

**Zoonotic disease (zoonosis):** Infectious disease that is naturally transmitted from animals to humans and vice versa.

## Foreword

The first edition of the World Health Organization (WHO) *Laboratory biosafety manual* was published in 1983. It encouraged countries to accept and implement basic concepts in biological safety and to develop national codes of practice for the safe handling of pathogenic biological agents in laboratories within their geographical borders. Since then, many countries have used the expert guidance provided in the manual to develop such codes of practice. The second and third editions of the *Laboratory biosafety manual* were published in 1993 and 2004 respectively. With each new version, WHO continues to provide international leadership on biosafety by addressing emerging issues, technologies and challenges, and providing guidance on best practice.

Previous versions of the manual described the classification of biological agents and laboratories in terms of risk/hazard groups and biosafety/containment levels. While this may be a logical starting point for the handling and containment of biological agents, it has led to the misconception that the risk group of a biological agent directly corresponds to the biosafety level of a laboratory. In fact, the actual risk of a given scenario is influenced not only by the agent being handled, but also by the procedure being performed and the competency of the laboratory personnel engaging in the laboratory activity.

This fourth edition of the manual builds on the risk assessment framework introduced in the third edition. A thorough, evidence-based and transparent assessment of the risks allows safety measures to be balanced with the actual risk of working with biological agents on a case-by-case basis. This will enable countries to implement economically feasible and sustainable laboratory biosafety and biosecurity policies and practices that are relevant to their individual circumstances and priorities.



# INTRODUCTION

Laboratory biosafety and biosecurity activities are fundamental to protecting the laboratory workforce and the wider community against unintentional exposures or releases of pathogenic biological agents. These activities are implemented using a risk assessment framework and through the development of a safety culture which is needed to ensure a safe workplace where adequate measures are applied to minimize the likelihood and severity of any potential exposure to biological agents. Biosafety awareness and expertise have improved greatly since previous editions of the World Health Organization's (WHO) *Laboratory biosafety manual (1-3)*. New technologies, such as the use of molecular methods, have advanced considerably and reduced the number of diagnostic activities that require propagation of high titre biological agents.

A review of recent laboratory-associated infections showed that most were caused by human factors rather than malfunctions of engineering controls (4,5). Factors that have led to potential and confirmed exposures to biological agents include an absence or improper use of personal protective equipment (PPE) (6,7), inadequate or ignored risk assessments (8), lack of standard operating procedures (SOPs) (9), needlestick injuries (10,11) and/or insufficiently trained personnel (12). It can be argued, therefore, that the best designed and most well engineered laboratory is only as good as its least competent worker.

The need to update international laboratory biosafety guidance is part of a broader initiative to globalize biosafety and emphasize the principles and approaches that are accessible to countries with a broad range of financial, technical and regulatory resources. WHO revised the *International Health Regulations* in 2005 "to help the international community to prevent and respond to acute public health risks that have the potential to cross borders and threaten people worldwide" (13). These regulations require all 196 WHO States Parties to be well prepared for potential outbreaks and new diseases; this includes early diagnosis and confirmation by laboratories to facilitate infection prevention and control. Biosafety and biosecurity are also one of the technical areas assessed by the monitoring and evaluation framework of the *International Health Regulations*. This indicates that safe and secure laboratory operations are essential components of compliance with the *International Health Regulations* and prevention of acute public health threats. This edition of the manual aims to guide sustainable developments in biosafety, including a national oversight system, training, best working practices and a risk assessment framework to promote a responsible safety culture that builds country capacity and complies with the *International Health Regulations*.

## 1.1 Intended scope

This fourth edition of the WHO *Laboratory biosafety manual* (LBM4) adopts a risk- and evidence-based approach to biosafety rather than a prescriptive approach in order to ensure that laboratory facilities, safety equipment and work practices are locally relevant, proportionate and sustainable. Emphasis is placed on the importance of a “safety culture” that incorporates risk assessment, good microbiological practice and procedure (GMPP) and SOPs, appropriate introductory, refresher and mentoring training of personnel, and prompt reporting of incidents and accidents followed by appropriate investigation and corrective actions. This new approach aims to facilitate laboratory design that ensures greater sustainability while maintaining an appropriate control of biosafety. For veterinary laboratories, this risk-based approach complements the recently revised World Organisation for Animal Health (OIE) standard for managing biological risk in the veterinary laboratory and animal facilities (14). The fourth edition of the manual provides a risk-based, technology-neutral and cost-effective approach to biosafety, with guidance on the feasibility of laboratory operations even in resource-limited settings. This approach lays a foundation for equitable access to clinical and public health laboratory tests, and encourages biomedical research opportunities, which are increasingly important to combat infectious disease outbreaks, without compromising safety.

The manual also provides an overview of biosecurity; however, this subject is covered in detail in another WHO guidance document (15). It does not cover animal pathogens unless they are zoonotic. For animal pathogens, reference should be made to the OIE standard for managing biological risks in the veterinary laboratories and animal facilities (14).

This publication provides guidance specifically for those who work with biological agents or in facilities where personnel may be exposed to potentially infectious substances that present a hazard to human health. It can be used to drive a safety culture for every day laboratory practices and procedures. It will also be of value to those building or renovating laboratory facilities and to countries developing or implementing biosafety programmes and national-level frameworks for biosafety oversight.

While the primary scope of this manual is laboratory biosafety as it pertains to the handling, management, and containment of biological agents and materials that pose a threat to human health, it is important to note that health and safety risk factors that are 1) related to biological agents and materials hazardous to plants, animals, and/or the environment and 2) not related to biological agents and materials should also be assessed because such hazards also exist in a laboratory setting. The risk- and evidence-based approach to biosafety and biosecurity of biological agents and materials outlined in the LBM4 can also be applied to risk management of non-biological hazards such as chemicals, physical hazards, adverse ergonomic conditions, allergens, and a broad range of psychosocial factors (for example, work-related stress) as well as biological hazards that pose an actual or potential threat to animal or environmental health, such as arthropod vectors containing gene drives for sterilization or transgenic laboratory animals with increased susceptibility to endemic or circulating biological agent(s).

Such broad application of the guidance outlined in the LBM4 facilitates a comprehensive, integrated approach to laboratory biosafety and biosecurity and promotes responsible laboratory use of biological agents and materials. Guidance documents and international best practice should be consulted for additional information in these areas (16).

## 1.2 How to use the *Laboratory biosafety manual*

This manual should complement any national regulation and oversight mechanisms that may be in place, and be used to assess, control and review risks at the local level. Therefore, the document covers the following areas:

- risk assessment, control and review,
- core requirements for biosafety,
- options for heightened control measures,
- maximum containment measures for very high-risk operations,
- transfer and transportation of infectious substances,
- biosafety programme management,
- laboratory biosecurity, and
- national and international biosafety oversight.

Associated monographs have also been produced to provide more detailed information and help implement systems and strategies on specialized topics. It is anticipated that this core document will be read first and the associated monographs can be referred to when more detailed information is required. The monographs include:

- biosafety programme management (17),
- risk assessment (18),
- biological safety cabinets and other primary containment devices (19),
- personal protective equipment (20),
- laboratory design and maintenance (21),
- decontamination and waste management (22), and
- outbreak preparedness and resilience (23).





# RISK ASSESSMENT

As described in the sections below, the control of biological risks – whether at national or organizational levels – is informed by performing a risk assessment. Risk assessment is the term used to describe the stepwise process in which the risk(s) arising from working with a hazard(s) are evaluated and the resulting information is used to determine whether risk control measures can be applied to reduce those risks to acceptable risks. Risk is the combination of the probability that a hazard will cause harm and the severity of harm that may arise from contact with that hazard.

In the case of laboratory biosafety, the hazards are biological agents whose pathogenic characteristics give them the potential to cause harm to humans or animals should they be exposed to these agents. The harm caused by exposure to biological agents can vary in nature and can range from an infection or injury to a disease or outbreak in larger populations (see Box 2.1).

## BOX 2.1 LIKELIHOOD AND CONSEQUENCE FOR LABORATORY BIOSAFETY

In the context of laboratory biosafety, likelihood refers to the potential for an exposure and/or a release outside of the laboratory. Consequence refers to the severity of the outcome from an exposure, if it were to occur. This could include a laboratory-associated infection, asymptomatic carriage, environmental contamination, spread of disease throughout the surrounding community or other illness or injury.

For this reason, factors that contribute to the occurrence of infection, such as routes of transmission, infectious dose and communicability, need to be considered in relation to the consequence of an exposure or release.

It is important to note that hazards alone do not pose a risk to humans or animals. For example, a vial of blood containing a biological agent such as Ebola virus does not pose a risk to the laboratory personnel until they come into contact with the blood contained within the vial. Therefore, the true risk associated with a biological agent cannot be determined by only identifying its pathogenic characteristics. Consideration must also be given to the types of procedure(s) that will be performed with the biological agent and the environment in which these procedures will take place. Any facility that handles biological agents has an obligation to their personnel and the community to perform a risk assessment on the work they will conduct and to select and apply appropriate risk control measures to reduce those risks to an acceptable risk. The purpose of the risk assessment is to gather information, evaluate it and use it to inform and justify the implementation of processes, procedures and technologies to control the risks present. Analysis of this information empowers laboratory personnel as it gives them a deeper understanding of the biological risks and the ways in which they can affect them. It helps create shared values, patterns of behaviour and perceptions of the importance of safety, and makes laboratory personnel more likely to conduct their work safely and maintain a safety culture in the laboratory.

Risk assessments must always be conducted in a standardized and systematic way to ensure they are repeatable and comparable in the same context. For this reason, many organizations offer risk assessment templates, checklists or questionnaires that provide stepwise approaches to identify, evaluate and determine risks associated with the hazards present, before using this information to identify appropriate risk control measures (24, 25). The various steps of the risk assessment process collectively form a risk assessment framework (Figure 2.1).



**Figure 2.1** The risk assessment framework

Where Figure 2.1 illustrates the steps in the risk assessment framework, Table 2.1 provides an overview of the key considerations that apply during each step of the cycle. It is important to note that not all factors will affect risk in the same way, but each should be carefully considered. When conducting a risk assessment, it must be remembered that the risk is not based on the pathogenicity of the biological agent alone, but on the likelihood and consequence of an incident occurring – in other words, the risk of exposure to and/or release of the biological agent during laboratory operations.

**Table 2.1** Key considerations in the risk assessment framework

STEP	KEY CONSIDERATIONS
<b>1. Gather information (hazard identification)</b>	<ul style="list-style-type: none"> <li>▪ What biological agents will be handled and what are their pathogenic characteristics?</li> <li>▪ What type of laboratory work and/or procedures will be conducted?</li> <li>▪ What type(s) of equipment will be used?</li> <li>▪ What type of laboratory facility is available?</li> <li>▪ What human factors exist (for example, what is the level of competency of personnel)?</li> <li>▪ What other factors exist that might affect laboratory operations (for example, legal, cultural, socioeconomic, public perception)?</li> </ul>
<b>2. Evaluate the risks</b>	<ul style="list-style-type: none"> <li>▪ How could an exposure and/or release occur?</li> <li>▪ What is the likelihood of an exposure and/or release?</li> <li>▪ What information gathered influences the likelihood the most?</li> <li>▪ What are the consequences of an exposure and/or release?</li> <li>▪ Which information/factor influences the consequences the most?</li> <li>▪ What is the overall initial risk of the activities?</li> <li>▪ What is an acceptable risk?</li> <li>▪ Which risks are unacceptable?</li> <li>▪ Can unacceptable risks be controlled, or should the work not proceed at all?</li> </ul>
<b>3. Develop a risk control strategy</b>	<ul style="list-style-type: none"> <li>▪ What resources are available for risk control measures?</li> <li>▪ What risk control strategies are most applicable for the resources available?</li> <li>▪ Are resources sufficient to obtain and maintain those risk control measures?</li> <li>▪ Are proposed control strategies effective, sustainable and achievable in the local context?</li> </ul>

**Table 2.1** Key considerations in the risk assessment framework (continued)

STEP	KEY CONSIDERATIONS
<b>4. Select and implement risk control measures</b>	<ul style="list-style-type: none"> <li>▪ Are there any national/international regulations requiring prescribed risk control measures?</li> <li>▪ What risk control measures are locally available and sustainable?</li> <li>▪ Are available risk control measures adequately efficient, or should multiple risk control measures be used in combination to enhance efficacy?</li> <li>▪ Do selected risk control measures align with the risk control strategy?</li> <li>▪ What is the residual risk after risk control measures have been applied and is it now acceptable?</li> <li>▪ Are additional resources required and available for the implementation of risk control measures?</li> <li>▪ Are the selected risk control measures compliant with national/international regulations?</li> <li>▪ Has approval to conduct the work been granted?</li> <li>▪ Have the risk control strategies been communicated to relevant personnel?</li> <li>▪ Have necessary items been included in the budget and purchased?</li> <li>▪ Are operational and maintenance procedures in place?</li> <li>▪ Have personnel been appropriately trained?</li> </ul>
<b>5. Review risks and risk control measures</b>	<ul style="list-style-type: none"> <li>▪ Have there been any changes in activities, biological agents, personnel, equipment or facilities?</li> <li>▪ Is there any new knowledge available of biological agents and/or the processes being used?</li> <li>▪ Are there any lessons learnt from incident reports and investigations that may indicate improvements to be made?</li> <li>▪ Has a periodic review cycle been established?</li> </ul>

It should be noted that laboratories worldwide could face unique challenges that will influence how various parts of the risk assessment framework are conducted. Challenges may include: the level of organizational and financial resources available to manage biological risks; absence of a reliable electrical supply; inadequate facility infrastructure; severe weather; under-staffed laboratories; and under-trained personnel. Furthermore, the status of national regulatory frameworks may influence the way in which risks are identified and controlled at a level higher than laboratory management, and compliance with any regulations should be a primary focus. For these reasons, the results of a risk assessment and the risk control measures implemented may vary considerably from laboratory to laboratory, institution to institution, region to region and country to country.

The following subsections describe in more detail the activities in each step of the risk assessment framework. They provide an overview of the most important components of risk assessments and the key considerations for conducting them. More detailed information on additional considerations and relevant templates can be found in *Monograph: risk assessment (18)*.

## 2.1 Gather information

Those conducting a risk assessment must collect and consider a wide range of information in order to accurately evaluate the risks and appropriately select the risk control measures needed to reduce risks to acceptable risks in the laboratory. This information goes beyond identifying the hazards – the biological agents being used – and considers the procedural and contextual situations that contribute to the overall risk (26). Key information to be gathered should include, for example:

- laboratory activities planned (for example, procedures, equipment, animal work, sonication, aerosolization and centrifugation),
- competency of the personnel carrying out the work,
- concentration and volume of the biological agent and potentially infectious material to be manipulated,
- potential routes of transmission,
- infectious dose of the biological agent,
- communicability of the biological agent,
- severity of infection with the biological agent,
- local availability of effective prophylaxis or therapeutic interventions,
- stability of the biological agent in the laboratory and external environment,
- susceptibility of laboratory personnel (for example, at-risk individuals),
- range of hosts of the biological agent (that is zoonotic potential),
- endemicity of the biological agent in the local population,
- frequency of equipment and building failures (for example, power, building infrastructure and systems).

All of the above-mentioned information collectively informs a much broader, multifactorial evaluation of risk that may exist in the laboratory. Information on all of these factors is essential as various combinations of biological agents and activities may pose greater risks in some situations than in others. For example, culturing a biological agent with a low infectious dose that is transmissible by the aerosol route might have a greater risk than culturing another biological agent with a high infectious dose that is only transmissible by the oral route. Or, performing research on a biological agent that is not prevalent in the local community will pose a greater risk than performing the work in a region where it is endemic.

It is important to remember that gathering information should also include defining the attributes of the laboratory environment, such as the condition of the building and laboratory areas where the work will be conducted. Improperly maintained structures can contribute to increased risks by increasing the probability of breakages or failures of features such as waste disposal or ventilation systems. Cracks in flooring and bench tops make disinfecting laboratory surfaces difficult, and can contribute to slips, trips, falls and dropped items containing biological agents.

Finally, information on human factors should also be considered, because the competence of laboratory personnel and their ability to follow established biosafety practice and procedure (in particular GMPP) are likely to have the greatest influence on the likelihood of incidents. Even the best designed and constructed facility or the most sophisticated equipment can only confer safety to its user if he/she is able to operate it correctly through proper training and proficiency practices.

### 2.1.1 Information on new or unknown biological agents

Where new biological agents are being used, or there are specimens for which detailed data are unknown, the information available may be insufficient to be able to carry out a comprehensive risk assessment. This applies to clinical specimens collected in the field during potential outbreak investigations. In such cases, it is sensible to take a cautious approach to specimen manipulation and handle all materials as potentially infectious. More information about biosafety in outbreak situations can be found in *Monograph: outbreak preparedness and resilience (23)*.

Certain information should be requested, where possible, to assist in determining the risks associated with handling such specimens including:

- medical data on the patient from whom the specimen was taken,
- epidemiological data (severity and mortality data, suspected route of transmission, other outbreak investigation data), and
- information on the geographical origin of the specimen.

In the case of an outbreak of a disease of unknown etiology, appropriate ad hoc guidelines can be produced and posted by competent national authorities and/or WHO to indicate how specimens are to be handled safely. This may include how specimens should be prepared for shipment as well as specific risk control measures that should be implemented.

## 2.2 Evaluate the risks

After gathering all available information on the circumstances of the work to be performed, it is necessary to use that information to identify and evaluate any risks that exist. The goal of the risk evaluation step is to:

- determine the likelihood of an exposure to and/or release of a biological agent occurring and the severity of the consequences of such an event,
- establish how the likelihood and consequence contribute to the initial risk of the work to be performed,
- decide, based on the gathered information of the risk assessment, whether these risks are acceptable or not; this decision must be justified and documented comprehensively.

If the evaluated risks are not acceptable, those performing the risk assessment should proceed to step 3 of the risk assessment framework and develop an appropriate risk control strategy, unless it is decided not to undertake the work at all. The primary considerations required during this risk evaluation step are outlined in the subsections below.

### 2.2.1 Determine the likelihood and consequences

Evaluation of the information gathered should first include the determination of likelihood of an exposure to and/or release of a biological agent occurring, and of the severity of the associated consequences. It is these factors, when considered together, that will ultimately determine the overall, or initial, risk of the situation for which the information has been gathered. This is illustrated in Box 2.2.

**BOX 2.2 EXAMPLE OF HOW LIKELIHOOD AND CONSEQUENCE INFLUENCE RISK**

Cigarette smoke is a common hazard.

The likelihood of exposure to cigarette smoke will differ depending on the situation. It will be greatest for an individual smoking a cigarette, moderate for those exposed to a smoker's second-hand smoke, and lowest for someone with respiratory protection or in smoke-free zones.

The consequences of exposure to cigarette smoke will range from mild nausea and respiratory irritation to various cardiac and pulmonary diseases to cancer and even death depending on the toxicity of the cigarette, frequency and duration of exposure and other factors related to human susceptibility.

Both likelihood and consequence must be considered when evaluating the risks associated with cigarette smoke. This example also shows how individuals evaluate and accept risk differently, given how prevalent smoking is despite the potential negative consequences. A similar risk assessment process for working with biological agents in the laboratory, weighing likelihood and consequence, is outlined in this section.

Examples of factors that can elevate the likelihood of an exposure to and/or release of biological agents during work in the laboratory, and/or escalate its associated consequences are given in Tables 2.2 to 2.4.

A low infectious dose is associated with a greater consequence from an exposure as the amount of the biological agent needed to cause a laboratory-associated infection is small. However, a low infectious dose does not affect the likelihood that an exposure occurs; this relies on factors associated with the work (Table 2.2).



**Table 2.2** Factors that affect the likelihood of an incident occurring

FACTORS ASSOCIATED WITH HIGH LIKELIHOOD OF INCIDENTS OCCURRING	RATIONALE
Laboratory activities associated with aerosolization (for example, sonication, homogenization, centrifugation)	When aerosols are generated by these methods, the likelihood of exposure through inhalation is increased, as is the likelihood of release of these aerosols into the surrounding environment where they might contaminate laboratory surfaces and also spread into the community.
Laboratory activities associated with sharps materials	When activities involve work with sharps, the likelihood of percutaneous exposure to a biological agent through a puncture wound is increased.
Low competency of personnel carrying out the work	Low proficiency of personnel in laboratory processes and procedures, through lack of experience, understanding or failure to comply with SOPs and GMPP, can lead to errors in performing the work which are more likely to result in exposure to and/or release of a biological agent. Cleaning and maintenance personnel must be trained before working close to a biological agent.
Highly environmentally stable biological agents	Biological agents that have settled on laboratory surfaces (for example, contamination caused by poor technique that allowed settling of aerosol or droplets after release) can be a source of inadvertent exposure as long as they remain stable in the environment, even if the contamination cannot be seen.
Inadequate or poor availability of electrical power, dilapidated laboratory facilities and building systems, malfunctioning equipment, damage from frequent severe weather and access of insects and rodents to the laboratory.	All these factors may result in partial breaches in, or complete failure of, biocontainment systems designed to reduce the likelihood of exposure to and/or release of biological agents.

GMPP = good microbiological practice and procedure; SOPs = standard operating procedures.

**Table 2.3** Factors that affect the consequences of an incident if it were to occur

FACTORS ASSOCIATED WITH GREATER CONSEQUENCES IF AN INCIDENT WERE TO OCCUR	RATIONALE
Low infectious dose	<p>For infection to occur in an exposed individual, a certain quantity (volume, concentration) of biological agent must be present. Even a small amount of an agent could result in severe consequences, such as a laboratory-associated infection.</p> <p>Furthermore, exposure to larger quantities of that agent (greater than the infectious dose) may result in a more severe presentation of the infection.</p>
High communicability	<p>Even one single exposure (causing carriage or a laboratory-associated infection) could rapidly spread from laboratory personnel or fomites to many individuals.</p>
High severity and mortality	<p>A laboratory-associated infection following exposure is more likely to cause personnel to become debilitated, lose their quality of life or die.</p>
Limited availability of effective prophylaxis or therapeutic interventions	<p>The symptoms or outcomes of a laboratory-associated infection cannot be effectively prevented, reduced or eliminated by a medical intervention. This may also include situations where medical intervention is not available, or emergency response capacity is limited.</p>
Large susceptible population (including laboratory personnel at increased risk)	<p>The larger the susceptible population, the more likely a laboratory-associated infection could rapidly spread and infect larger numbers of people.</p>
Lack of endemicity (such as exotic disease)	<p>When an agent is not endemic in the surrounding population, the population is more likely to be susceptible to the agent, leading to an increased likelihood of a laboratory-associated infection spreading to the community.</p>

**Table 2.4** Factors associated with both a high likelihood of and greater consequences from a potential incident

FACTORS ASSOCIATED WITH BOTH A HIGH LIKELIHOOD OF AND GREATER CONSEQUENCES FROM A POTENTIAL INCIDENT HIGHER LIKELIHOOD AND GREATER CONSEQUENCE	RATIONALE
<p><b>High concentration or volume of the biological agent</b></p>	<p>The more biological agent there is in the substance being handled, the more infectious particles there will be available for exposure, and the more likely the exposure volume will contain the infectious dose of that agent.</p> <p>Furthermore, being exposed to a higher concentration of the agent could result in a more severe infection, illness or injury.</p>
<p><b>Airborne route of transmission</b></p>	<p>Biological agents with an airborne route of transmission may be capable of remaining airborne in aerosols for prolonged periods of time and may disseminate widely in the laboratory environment, increasing the likelihood that personnel may be exposed to the agent.</p> <p>Furthermore, following an exposure event, aerosolized biological agents may be inhaled and deposit on the respiratory tract mucosa of the exposed individual, possibly leading to a laboratory-associated infection.</p>

### 2.2.2 Determine the initial risk

The information gathered must then be used to establish how much risk a particular situation presents (for example, how likely and how severe). Table 2.5 shows a risk assessment matrix which provides a simplified example of how to assess the relationship between likelihood and consequence in order to determine the initial risk of exposure to and/or release of a biological agent. In reality, the relationship comparison may include a broader or more complex range of values for determining likelihood and consequence than that which is shown in Table 2.5, but it is a useful tool to demonstrate how the initial risk can change relative to these independent factors. In addition to the method described here, there are further methods to determine initial risk and prioritize risks for the implementation of risk control measures. Institutions should employ a risk prioritization strategy that best meets their unique needs while acknowledging the limitations of the selected strategy and ensuring that professional judgement remains a critical part of the risk prioritization process.

**Table 2.5** Risk assessment matrix

Consequences of exposure/ release	Severe	Medium	High	Very high
	Moderate	Low	Medium	High
	Negligible	Very low	Low	Medium
		Unlikely	Possible	Likely
		Likelihood of exposure/release		

### 2.2.3 Establish an acceptable risk

Once the initial risk has been evaluated, it is necessary to determine whether this risk is acceptable to allow work to proceed. If it is not, a risk control strategy will be required to reduce and sustainably control those risks appropriately as described in the next step of the risk assessment framework.

It is important to acknowledge that there will never be zero risk, unless the work is not conducted at all, so a balance must be carefully managed between conducting the work and ensuring that personnel and the community are as safe as possible from inadvertent exposure to and/or release of biological agents. It is also important to recognize that the work being performed in the laboratory offers considerable benefits to both health care and global health security that justifies a certain degree of risk. Determining the acceptable risk is essential in providing a benchmark below which the initial risk must be reduced in order for work to be considered safe enough to proceed.

*It is important to note that risk can never be completely eliminated unless the work is not performed at all. Therefore, determining if the initial and/or residual risks are acceptable, controllable or unacceptable is a vital part of the risk evaluation process.*

Beyond what is regulated by national legislation and policies (27), the acceptable risk must be established by an organization itself so that it is proportionate to the organization's situation and resources. Consideration must be given to organizational risks such as compliance risk (legal action, fines, citations), security risk (theft or loss), environmental risk (socioeconomic impact on community health and agriculture), and even perceived risk (subjective judgements or uncertainty about the severity of risk). Perceived risks of the personnel should be taken seriously. Self-introduced risk control measures by the personnel should be avoided.

Taking into consideration the risk perceptions of relevant stakeholders (for example, government departments, donors, audit/oversight agencies, the general public and the local community), especially where high actual risks are involved, may be useful to allay the fears of those stakeholders who might otherwise be resistant (for example, politically or administratively) to the laboratory performing its usual functions.

## 2.3 Develop a risk control strategy

Once an acceptable risk has been established, a risk control strategy must be developed to reduce any initial risks to an acceptable risk and allow the work to proceed safely. As previously mentioned, because elimination of risk is not generally possible in practice, careful selection of a risk control strategy is required to ensure that risks are prioritized against the available resources with the understanding that a low acceptable risk will require many more resources to implement and maintain the relevant risk control measures needed to reduce the risk. Acceptable risk, however, must not be raised unnecessarily as a substitute for making resources available to fulfil the necessary risk control strategy and provide the appropriate protection. Resources must be made available or work should not proceed.

There are a number of different strategies that may be used to reduce and control risks. Often, more than one risk control strategy may need to be applied in order to reduce the risks effectively. Table 2.6 provides an overview of some of the most common strategies employed for risk control and examples of the risk control measures.

A good risk control strategy will:

- provide an overall direction of the nature of the risk control measures that may be required to reduce unacceptable risks, without stipulating necessarily the types of risk control measures that can be used to achieve this reduction,
- be achievable using the available resources in the context of the local conditions,
- help minimize any resistance to the work being performed (for example, addresses the risk perceptions of relevant stakeholders) and secure support (for example, approvals from national/international regulatory authorities),
- align with the overall goals, objectives and mission of the organization and facilitate success (that is improves public health and/or health security).

**Table 2.6** Strategies for risk reduction

STRATEGY	EXAMPLE
Elimination	Eliminate the hazard: <ul style="list-style-type: none"> <li>▪ use an inactivated biological agent,</li> <li>▪ use a harmless surrogate.</li> </ul>
Reduction and substitution	Reduce the risk: <ul style="list-style-type: none"> <li>▪ substitute with an attenuated or less infectious biological agent,</li> <li>▪ reduce the volume/titre being used,</li> <li>▪ change the procedure for one that is less hazardous, such as polymerase chain reaction rather than culture.</li> </ul>
Isolation	Isolate the hazard: <ul style="list-style-type: none"> <li>▪ elimination and reduction might not be possible, particularly in a clinical setting, therefore isolate the biological agent(s) (for example, in a primary containment device).</li> </ul>
Protection	Protect personnel/the environment: <ul style="list-style-type: none"> <li>▪ use engineering controls (for example, BSC),</li> <li>▪ use PPE,</li> <li>▪ vaccinate personnel.</li> </ul>
Compliance	Have administrative controls and effective biosafety programme management in place such as: <ul style="list-style-type: none"> <li>▪ GMPP observed by personnel,</li> <li>▪ good communication of hazards, risks and risk control measures,</li> <li>▪ appropriate training,</li> <li>▪ clear SOPs,</li> <li>▪ an established safety culture.</li> </ul>

BSC = biological safety cabinet; GMPP = good microbiological practice and procedure; PPE = personal protective equipment; SOPs = standard operating procedures.

## 2.4 Select and implement risk control measures

Once a risk control strategy has been developed, risk control measures must be selected and then implemented in order to fulfil the risk control strategy. In some cases, the nature of the risk control measures required will be predetermined, prescribed by a set of minimum standards for risk control (for example, by internationally accepted best practice, national/international regulations).

However, for some cases, a variety of risk control measures will be available to appropriately achieve the risk control strategy depending upon the nature of the risk identified, the available resources, and other local conditions.

It must be remembered that even after a risk control measure is selected for your risk strategy, a certain degree of risk will still remain. If that risk, known as the residual risk, is still unacceptable, additional and/or more effective risk control measures may need to be used to fulfil the risk control strategy and bring the risk to an acceptable risk. Usually, the higher the initial risk, the greater the number of risk control measures needed to reduce the residual risk to an acceptable risk for work to continue.

However, the relative effectiveness of each available risk control measure to reduce the evaluated risks will also affect how many risk control measures are needed to close the gap between the residual risk and the acceptable risk. Furthermore, the use of multiple risk control measures in combination to reduce the residual risk may have further benefits in building redundancy in case of failure of one or more of the selected risk control measures.

The following subsections provide an overview of the key considerations required for the selection and implementation of risk control measures in order to fulfil the risk control strategy.

### 2.4.1 Select risk control measures

When selecting laboratory risk control measures, national regulations and guidelines must always be considered first to ensure compliance. These may be verified through inspections, certifications, audits and assessments, and be overseen by nationally appointed authorities.

The remainder of this subsection describes the selection of risk control measures at the laboratory level, outside those required by any national regulations that may be in place.

For most laboratory activities, the likelihood of exposure and/or release is unlikely, with a negligible to moderate severity of consequences. This means the initial risk is very low or low and is often near or below the acceptable risk even before risk control measures are applied. International guidance and accepted best practice for biosafety recommend the adoption of a basic set of biosafety principles, technologies and practices to act as risk control measures to ensure that all work remains below the accepted risk. For this reason, this manual provides a minimum set of risk control measures to be implemented during any work with biological agents. This combination of risk control measures is known collectively as the core requirements and include tools, training, and physical and operational controls considered necessary to work safely in most laboratory situations. These requirements are described in more detail in section 3 core requirements. However, it is important to note that despite the low risk, GMPP still needs to be promoted and laboratory activities needs to be reviewed periodically to ensure that GMPP and all the core requirements are effectively implemented to complete the risk assessment framework.

*The majority of clinical and diagnostic laboratory work will require only the prescribed core requirements to effectively control risks.*

For cases where initial risks fall into higher categories, a selection of additional risk control measures will be required in addition to the core requirements. Examples of factors associated with a likely or possible likelihood of and/or severe consequence of an incident occurring are shown in Tables 2.2 to 2.4. Under such circumstances, the additional risk control measures selected to reduce the residual risk to an acceptable risk are considered heightened control measures.

Biological agents and procedures that require heightened control measures may vary, ranging from culture and propagation of biological agents in small volumes with a medium risk to large-scale work with drug-resistant strains or animal studies with aerosol-transmissible, zoonotic agents, which are considered high risk. The heightened control measures should be appropriate and proportionate to address the specific factor(s) that contributes to the likelihood and/or consequence of an exposure and/or release; for example, a procedure with an aerosol risk should have a risk control measure that is effective at capturing aerosols. For this reason, the most appropriate heightened control measure will also vary considerably depending on the biological agents being handled, procedures being performed and potential transmission routes. All heightened control measures will have advantages and disadvantages that must be carefully considered when selecting the appropriate ones to close the gap between the residual risk and the acceptable risk.

Where the evaluated risks are considered high on the risk spectrum, cost-benefit analyses should be undertaken to assess options such as outsourcing the work (to a suitable facility that has the appropriate risk control measures and resources in place), as well as a detailed evaluation of heightened control measures that could be implemented to enhance the laboratory facility. The risk control measures chosen will be most effective when they are selected to meet local needs.

*It is important to note that while a hierarchy of risk control measures has been defined by many countries, it cannot be assumed that one risk control measure is always preferable to another (such as engineering controls versus personal protective equipment).*

Usually, heightened control measures should be selected based on available evidence of their effectiveness, either through peer-reviewed studies or other reliable sources of information. Where reliable information does not exist, in-house validation of risk control measures may be required. Where applicable, publishing in-house validation in peer-reviewed journals should be considered so that others can benefit from the conclusions of such studies. This includes new information, previous incidents and the effectiveness of and the protection afforded by the risk control measures. Such studies may also help highlight the likelihood of exposure associated with specific equipment or procedures, which can be included in future information-gathering activities and be used to inform the risk evaluation step in the risk assessment framework.



Some of the most commonly used heightened control measures are discussed in more detail in section 4 heightened control measures, including their relative effectiveness when used in different local conditions.

Where heightened control measures are applied, it is important to recalculate the residual risk after a risk control measure is selected and estimate whether this has effectively brought the residual risk to the acceptable risk. This requires a re-evaluation of the residual risk, guided by questions such as:

- Has the possibility of an exposure/release become less likely to happen?
- Have the consequences become less severe?
- Have the likelihood and consequences been reduced such that the residual risk is acceptable?
- If no, are additional risk control measures available?
- Should work proceed, with or without which risk control measures?
- Who has the authority to accept the residual risk and approve the work to go ahead?
- How should the selected risk control measures and subsequent approval for work to proceed be documented?

In very rare situations, there may be a very high likelihood of exposure and/or release. However, more important is the possibility of severe consequences from any exposure and/or release if it were to occur. Such cases include work with globally eradicated pathogens, or with highly transmissible animal pathogens that could spread rapidly in susceptible populations upon release and cause widespread panic, and decimation of species and/or livelihoods. The risk would be further increased if the agent were propagated in liquid media, particularly if in large volumes, and if infectious aerosols were produced (for example, in vaccine development studies). In such cases, a very high initial risk of exposure to and/or release of a biological agent exists which will likely require a highly specialized, highly effective set of risk control measures to reach an acceptable risk, if the work is to be performed at all. This includes a large set of strict and complicated operational practices, safety equipment and facility design criteria which can be referred to as maximum containment measures; these are described in more detail in section 5 maximum containment measures. As maximum containment measures are necessary to provide the highest protection against the most severe consequences of an exposure or release, evaluating the feasibility of effectively implementing and maintaining maximum containment measures is an extremely important and necessary exercise. This would require frequent and rigorous verification of procedures, equipment and laboratory facilities. Periodic review must also include analysis of ongoing studies to ensure they are adequately justified with the scientific benefits outweighing the biosafety risks.

While an overview of the commonly employed maximum containment measures are presented in this manual, the specialized and complex facilities and expertise required to implement maximum containment measures are only available in a very few laboratories worldwide.

Implementing risk control measures of this complexity requires careful individual consideration by experienced international experts as well as coordination by many sectors, normally including government. For this reason, it is not possible to provide a specific set of requirements applicable to each situation that is considered to require maximum containment measures.

The following schematic (Figure 2.2) summarizes the risk outlined in Table 2.5 (the risk assessment matrix) and associates the risks with the types of risk control measures likely to be required. It highlights the following:

- Most laboratory activities can be safely executed using core requirements, where the risks are very low to low,
- Some laboratory activities will require heightened control measures to safely control the associated risks, which may be medium to high, and
- A very small amount of laboratory work will require maximum containment measures due to very high risks, particularly those risks associated with catastrophic consequences.

#### 2.4.2 Implement risk control measures

Once the appropriate combination of risk control measures has been selected, necessary approvals should be obtained. A proper review of cost, availability of funding, installation, maintenance, and security and safety criteria should be undertaken to ensure that the risk control measure(s) can be effectively used as part of the risk control strategy and can be sustained by the available laboratory resources. Each person operating laboratory equipment must be trained on the correct operating procedures required for each and every risk control measure in the laboratory, which may require SOPs to be written or updated. Consideration should also be given to ensuring that the risk control measures selected will not introduce their own risks to the work. For example, multiple layers of PPE might increase the likelihood of mistakes occurring because of reduced dexterity or increase the likelihood of contamination if it is difficult to remove, thereby increasing the overall risk of exposure. Non-biological risk factors of the selected risk control measures should also be considered; for example, specialized design features of furniture or equipment should not introduce ergonomic problems for personnel.

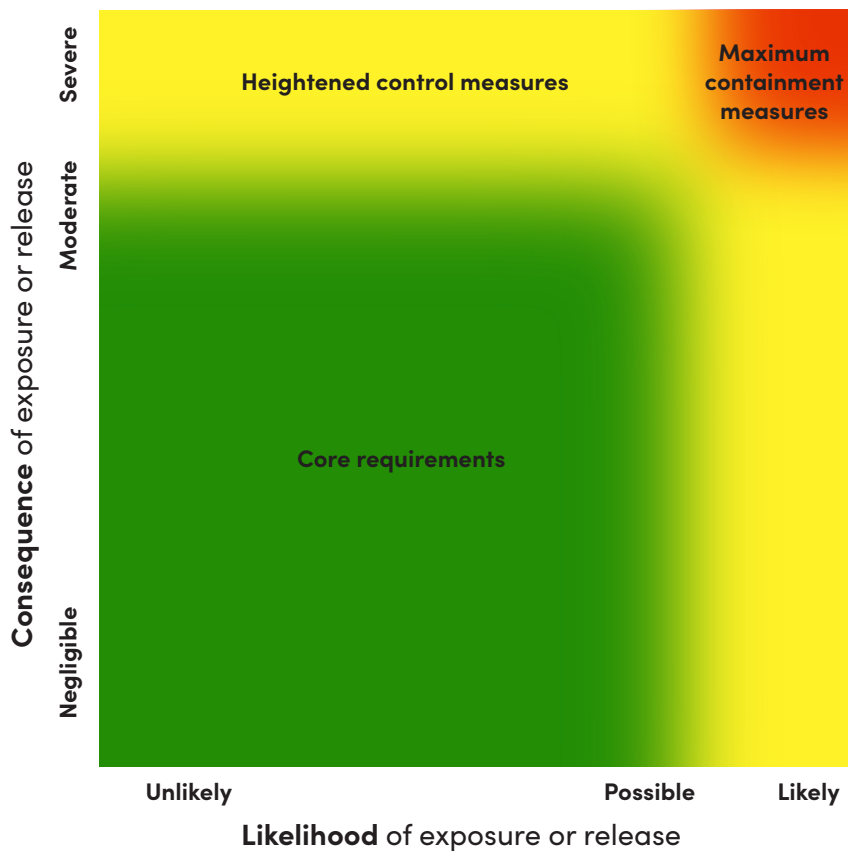

**Figure 2.2** Risk control measures needed based on the likelihood and consequence of exposure or release

Finally, once risk control measures have been selected, approved and acquired, information about their purpose, function and use must be communicated to all applicable personnel if they are to be implemented correctly and be effective. Communication is a vital part of biosafety and risk assessment. Without it, it is unlikely that the risk control measures will reduce residual risk. All those working in the laboratory are responsible for following the appropriate practices and procedures of any risk reduction strategy that applies to them and for providing feedback on their effectiveness. To achieve the appropriate level of awareness, training and competency for implementation of risk control measures and safe laboratory operation requires, at a minimum, communication of the hazards (biological agents) present, communication of the risks associated with the procedures being performed and communication of exactly how the risk control measures used can most effectively reduce those risks. Strategies for communication and outreach beyond traditional biosafety training include laboratory-specific SOPs, interactive team discussions, job aids and posters, generic awareness-raising through short publications (for example, pamphlets, handouts), briefings and email notifications.

Table 2.7 provides some basic examples of laboratory activities and shows how the application of risk control measures affects the residual risk.

**Table 2.7** Examples of laboratory activities, their initial risk, and residual risk after application of appropriate risk control measures

PROCEDURE	INITIAL RISK (LIKELIHOOD/ CONSEQUENCE)	RISK CONTROL MEASURE(S)	RESIDUAL RISK
Polymerase chain reaction analysis of inactivated sputum specimen	Very low (Unlikely/ Negligible)	CR	Very low
Smear preparation and microscopy of sputum specimen	Low (Unlikely/ Moderate)	CR	Very low
Culture on solid media for antibiotic sensitivity testing	Medium (Possible/ Moderate)	HCM (for example, CR plus respiratory protective equipment)	Low
Culture in small quantities (< 50 mL) for strain characterization including antibiotic resistant strains	High (Likely/ Moderate)	HCM (for example, CR plus biological safety cabinet)	Low/Medium
Culture in large quantities (> 10 L) for animal challenge study via aerosol route	High (Possible/ Severe)	HCM (for example, CR plus biological safety cabinet and respiratory protective equipment)	Medium
Biological agent has been globally eradicated with studies ongoing with above procedures	Very high (Likely/ Severe)	MCM	Medium

CR = Core requirements; HCM = Heightened control measures; MCM = Maximum containment measures. Note: Unless otherwise noted, the biological agent considered in the above scenarios has a low infectious dose, is transmitted via aerosol route and is susceptible to available treatments.

The goal of risk communication is to help all stakeholders, including laboratory personnel, involved in the implementation of risk reduction strategies to understand the risk assessment method(s), results and risk control measure decisions. Risk communication is vital to allow laboratory personnel to make informed choices about how to perform their role in the laboratory and to establish a successful safety culture built around effective risk-reduction strategies.

Furthermore, strong communication practices will help establish good reporting mechanisms for any incidents, accidents or inefficiencies of the risk control measures. Risk communication also plays an important role in the laboratory's relationship with outside stakeholders, such as regulatory authorities and the general public. Maintaining open communication lines will also be beneficial when conducting future assessments. Written documents are essential to maintain an accurate and historical record of risk assessments and communicating the results to laboratory personnel.

## 2.5 Review risks and risk control measures

Once performed, risk assessments must be reviewed routinely and revised when necessary, taking into consideration new information about the biological agent, changes in laboratory activities or equipment and new risk control measures that may need to be applied. Suitable procedures must be put in place not only to ensure implementation and reliability of the risk control measures, but also to ensure that they are sustainable. Confirmation that measures are effective and that training has been carried out appropriately can be verified through inspection, review and audit of processes and documentation. This will also provide an opportunity for improvements to be made to the processes and associated safeguards. This will include a careful review of laboratory-associated infections, incidents, accidents as well as literature reviews and relevant references.

As was indicated for the initial risk assessment, recording the results of the reassessment is also important in order to document the decisions made, which will facilitate future reviews and performance evaluations.

A risk assessment must therefore be performed and reviewed periodically, at a frequency that corresponds to the risk of the laboratory work. Typically, an annual review is adequate; however, some situations may prompt an ad hoc review, such as a biosafety incident, or feedback from the laboratory personnel on the effectiveness and ease of use of the risk control measures that have been implemented.

*When laboratory activities, personnel, processes and technology change, so does the risk.*

Activities or events that affect the risk and will therefore trigger a risk reassessment include:

- changes to biological agents, or new information available on current biological agents,
- changes to personnel,
- changes to procedures and practices,
- changes to laboratory equipment,
- changes in international, national or regional regulations or guidelines,
- changes in national or regional disease status (endemicity of disease or eradication),
- introduction of new technology,
- laboratory relocation or renovation,
- an incident, accident, laboratory-associated infection, or any event where a potential for harm is identified,
- identification and/or implementation of corrective and/or preventive action,
- user feedback, and
- periodic review.

Whenever a reassessment is warranted, the next step is to return to the beginning of the risk assessment process where new information will be gathered relating to the change, risks will be re-evaluated and it will be determined whether new risk control measures need to be implemented. This ongoing cycle of risk assessment continues to apply throughout the duration of the laboratory work.

# CORE REQUIREMENTS

**Core requirements** is the term used to describe a combination of risk control measures that are both the foundation for, and an integral part of, laboratory biosafety. These measures, outlined in this section, reflect international standards and best practice in biosafety that act as a set of minimum requirements and considerations that are necessary to work safely with biological agents, even where the associated risks are minimal. These requirements are comprehensive and detailed as they are fundamental to all laboratory facilities. However, where determined by the risk assessment, additional requirements and considerations may be needed for more effective risk control, over and above these core requirements. These additional requirements are described in sections 4 and 5, and are the heightened control measures and maximum containment measures respectively proposed to address the higher initial risks associated with the performance of more specialized work and/or work with more hazardous biological agents. For most procedures used in diagnostic and clinical laboratories, following core laboratory requirements will be sufficient to work safely with most biological agents.

The core requirements include a set of operational and physical elements that, when combined, should be sufficient to control the risks of most procedures with most biological agents in clinical and diagnostic laboratories. As previously mentioned, all the risk control measures implemented as part of the core requirements must be appropriately managed in order to help ensure a safe working environment, as described in section 7 biosafety programme management.

## 3.1 Good microbiological practice and procedure

It is important to recognize that perhaps the most substantial risk control measures to be embedded as a core requirement is that of GMPP. GMPP is a term given to a set of standard operating practices and procedures, or a code of practice, that is applicable to all types of activities with biological agents. This includes both **general behaviours, best working practice and technical procedures** that should always be observed in the laboratory and conducted in a standardized way. The implementation of standardized GMPP serves to protect laboratory personnel and the community from infection, prevent contamination of the environment, and provide product protection for the work with the biological agents in use.

GMPP are the most essential risk control measures because human error, suboptimal laboratory techniques and improper use of equipment have been found to cause the most laboratory injuries and laboratory-associated infections (4,28-30).

It is essential that laboratory personnel are trained and proficient in GMPP to ensure safe working practices. GMPP should be part of academic training for biological, veterinary and medical science students and be part of the national or institutional syllabus. Without GMPP, risk cannot be controlled sufficiently, even if other physical risk control measures are in place. Additional operational practices and procedures may be required for work where higher risks have been determined in the risk assessment, such as those described in sections 4 and 5. However, GMPP will always be applicable. GMPP include general behaviours, best practice, and technical procedures (such as aseptic techniques) which together help protect both the laboratory personnel and the specimens themselves from exposure to and/or release of biological agents.

### 3.1.1 Best practice

Best practice describes behaviours that are essential to facilitate safe work practices and control biological risks. Examples of laboratory best practice are outlined below.

- Never store food or drink, or personal items such as coats and bags in the laboratory. Activities such as eating, drinking, smoking, and applying cosmetics are only to be performed outside the laboratory.
- Never put materials, such as pens, pencils or gum, in the mouth while inside the laboratory, regardless of whether gloves are worn or not.
- Wash hands thoroughly, preferably with warm running water and soap, after handling biological material and/or animals, before leaving the laboratory or when hands are known or believed to be contaminated.
- Ensure open flames or heat sources are never placed near flammable supplies and are never left unattended.
- Ensure that cuts or broken skin are covered before entering the laboratory.
- Before entering the laboratory, ensure that there are adequate supplies of laboratory equipment and consumables, including reagents, PPE and disinfectants, and that these items are suitable for the activities envisaged.
- Ensure that supplies are stored safely and according to storage instructions to reduce accidents and incidents such as spills, trips and falls.
- Ensure proper labelling of all biological agents and chemical and radioactive material.
- Protect written documents from contamination using barriers (such as plastic coverings), particularly those that may need to be removed from the laboratory.
- Ensure that the work is performed with care and without hurrying. Avoid working when fatigued.



- Keep the work area tidy, clean and free of non-essential objects and materials.
- Prohibit the use of earphones, which can distract personnel and prevent equipment or facility alarms from being heard.
- Cover or remove any jewellery that could tear gloves, easily become contaminated or become fomites. Cleaning and decontamination of jewellery or spectacles should be considered, if such items are worn regularly.
- Refrain from using portable electronic devices (for example, mobile telephones, tablets, laptops, flash drives, memory sticks, cameras, or other portable devices, including those used for DNA/RNA sequencing) when not specifically required for the laboratory procedures being performed.
- Keep portable electronic devices in areas where they cannot easily become contaminated or act as fomites that transmit infection. Where close proximity of such devices to biological agents is unavoidable, ensure the devices are either protected by a physical barrier or decontaminated before leaving the laboratory.

### 3.1.2 Technical procedures

Technical procedures are a special subset of GMPP which relate directly to controlling risks through safe conduct of laboratory techniques. These technical procedures, when executed correctly, allow work to be performed in a manner that minimizes the likelihood of cross contamination (that is contamination of other specimens, or previously sterile substances or objects as well as surface contamination) and also help prevent exposure of the laboratory personnel to biological agents. The following procedures help avoid certain biosafety incidents occurring.

#### Avoiding inhalation of biological agents

- Use good techniques to minimize the formation of aerosols and droplets when manipulating specimens. This includes refraining from forcibly expelling substances from pipette tips into liquids, over-vigorous mixing, and carelessly flipping open tubes. Where pipette tips are used for mixing, this must be done slowly and with care. Brief centrifuging of mixed tubes before opening can help move any liquid away from the cap.
- Avoid introducing loops or similar instruments directly into an open heat source (flame) as this can cause spatter of infectious material. Where possible, use disposable transfer loops, which do not need to be resterilized. Alternatively, an enclosed electric microincinerator to sterilize metal transfer loops can also be effective.

### Avoiding ingestion of biological agents and contact with skin and eyes

- Wear disposable gloves at all times when handling specimens known or reasonably expected to contain biological agents. Disposable gloves must not be reused.
- Avoid contact of gloved hands with the face.
- Remove gloves aseptically after use and wash hands as outlined in *Monograph: personal protective equipment (20)*.
- Shield or otherwise protect the mouth, eyes and face during any operation where splashes may occur, such as during the mixing of disinfectant solutions.
- Secure hair to prevent contamination.
- Cover any broken skin with a suitable dressing.
- Prohibit pipetting by mouth.

### Avoiding injection of biological agents

- Wherever possible, replace any glassware with plastic-ware.
- If required, use scissors with blunt or rounded ends rather than pointed ends.
- If glassware must be used, check it on a regular basis for integrity and discard it if anything is broken, cracked or chipped.
- Use ampoule openers for safe handling of ampoules.
- Minimize the risk associated with the use of syringes or needles by using blunt syringe needles, alternative devices or engineered sharp safety devices where possible. However, be aware that sharp safety devices also pose a risk when not handled properly.
- Never use syringes with needles as an alternative to pipetting devices.
- Never re-cap, clip or remove needles from disposable syringes.
- Dispose of any sharps materials (for example, needles, needles combined with syringes, blades, broken glass) in puncture-proof or puncture-resistant containers fitted with sealed covers. Disposal containers must be puncture-proof/-resistant, must not be filled to capacity (three-quarters full at most), must be never reused and must not be discarded in landfills.

### Preventing dispersal of biological agents

- Discard specimens and cultures for disposal in leak-proof containers with tops appropriately secured before disposal in dedicated waste containers.
- Place waste containers, preferably unbreakable (such as plastic, metal), at every workstation.
- Regularly empty waste containers and securely dispose of waste.
- Ensure all waste is properly labelled.
- Consider opening tubes with disinfectant-soaked pad/gauze.
- Decontaminate work surfaces with a suitable disinfectant at the end of the work procedures and if any material is spilled.
- When disinfectants are used, ensure the disinfectant is active against the agents being handled and is left in contact with waste materials for the appropriate time, according to the disinfectant being used.

## 3.2 Personnel competence and training

Human error and poor technical skills can compromise the best safeguards. Thus, competent and safety-conscious laboratory personnel, who are well informed on how to recognize and control laboratory risks, are essential for the prevention of laboratory-associated infections and/or other incidents. Table 3.1 outlines the training that must be implemented for laboratory personnel.

An effective safety programme begins with financial and administrative support from the laboratory management that enables and assures safe laboratory practices and procedures are integrated into the training of all personnel.

Measures to ensure that employees have read and understood the guidelines, such as signature pages, must be adopted. Laboratory supervisors have the main role in training their immediate personnel in GMPP.

## 3.3 Facility design

The facility design features listed below are core requirements for biosafety for all laboratories handling biological agents.

- Ample space must be provided for the safe conduct of laboratory work and for cleaning and maintenance.

**Table 3.1** Training to be implemented for laboratory personnel

TRAINING	AREAS TO BE COVERED
<b>General familiarization and awareness training</b>	Mandatory for ALL personnel, an introduction to: <ul style="list-style-type: none"> <li>▪ Laboratory layout, features and equipment</li> <li>▪ Laboratory code(s) of practice</li> <li>▪ Applicable local guidelines</li> <li>▪ Safety or operations manual(s)</li> <li>▪ Institutional policies</li> <li>▪ Local and overarching risk assessments</li> <li>▪ Legislative obligations</li> <li>▪ Emergency/incident response procedures</li> </ul>
<b>Job-specific training</b>	<ul style="list-style-type: none"> <li>▪ Training to be determined based on job function; training requirements may vary between personnel of the same job title but performing different functions</li> <li>▪ All personnel involved in the handling of biological agents must be trained on GMPP</li> <li>▪ Competency and proficiency assessment must be used to identify any other specific training required, for example, by observation and/or qualification</li> <li>▪ Proficiency in any procedure must be verified before working independently, which may require a mentorship period</li> <li>▪ Competencies must be reviewed regularly and refresher training undertaken</li> <li>▪ Information on new procedures, equipment, technologies and knowledge must be communicated to applicable personnel as and when available</li> </ul>
<b>Safety and security training</b>	Mandatory for ALL personnel: <ul style="list-style-type: none"> <li>▪ Awareness of hazards present in the laboratory and their associated risks</li> <li>▪ Safe working procedures</li> <li>▪ Security measures</li> <li>▪ Emergency preparedness and response</li> </ul>

GMPP = good microbiological practice and procedure.

- Designated hand-washing basins operated by a hands-free mechanism must be provided in each laboratory room, preferably close to the exit door.
- The laboratory must be a restricted-access area. Laboratory entrance doors should have vision panels (to avoid accidents during opening), appropriate fire ratings and preferably be self-closing.
- Doors must be appropriately labelled with the international biohazard warning symbols wherever biohazardous materials are handled and stored.

- Laboratory walls, floors and furniture must be smooth, easy to clean, impermeable to liquids and resistant to the chemicals and disinfectants normally used in the laboratory.
- Laboratory bench tops must be impervious to water and resistant to disinfectants, acids, alkalis, organic solvents and moderate heat.
- Laboratory furniture must be fit for purpose. Open spaces between and under benches, cabinets and equipment must be accessible for cleaning.
- Laboratory lighting (illumination) must be adequate for all activities. Daylight should be utilized effectively to save energy. Undesirable reflections and glare should be avoided. Emergency lighting must be sufficient to permit safe stopping of work as well as safe exit from the laboratory.
- Laboratory ventilation where provided (including heating/cooling systems, especially fans/local cooling split-system air conditioning units – specifically when retrofitted) should ensure airflows do not compromise safe working. Consideration must be given to resultant airflow speeds and directions, and turbulent airflows should be avoided; this applies also to natural ventilation.
- Laboratory storage space must be adequate to hold supplies for immediate use to prevent clutter on bench tops and in aisles. Additional long-term storage space, conveniently located outside of the laboratory room/space, should be considered.
- Space and facilities must be provided for the safe handling and storage of chemicals and solvents, radioactive materials, and compressed and liquefied gases if used.
- Facilities for storing food and drink, personal items, jackets and outerwear must be provided outside the laboratory.
- Facilities for eating and drinking must be provided outside the laboratory.
- First-aid facilities must be readily accessible and suitably equipped/stocked.
- Appropriate methods for decontamination of waste, for example, disinfectants and autoclaves, must be available in proximity to the laboratory.
- The management of waste must be considered in the design. Safety systems must cover fire, electrical emergencies and emergency/incident response facilities based on risk assessment.
- There must be a reliable and adequate electricity supply and lighting to permit safe exit.
- Emergency situations must be considered in the design as indicated in the local risk assessment and should include the geographical/meteorological context.

- Fire security and flood risk must be considered.

For further information and an expansion of these core laboratory requirements and recommendations, refer to *Monograph: laboratory design and maintenance (21)*.

### 3.4 Specimen receipt and storage

Safe handling of biological agents begins even before a specimen arrives in the laboratory. When not properly packaged, infectious substances received in the laboratory can pose a safety risk to personnel. The following subsections describe the risk control measures that should be in place when receiving, storing and inactivating specimens as part of the core requirements for biosafety. For more information on the control requirements for handling biological agents before they reach the laboratory (that is while in transit), please refer to section 6 transfer and transport.

#### 3.4.1 Receiving specimens

A specimen received by the laboratory must be accompanied by sufficient information to identify what it is, when and where it was taken or prepared, and which tests and/or procedures (if any) are to be performed.

Personnel unpacking and receiving specimens must be adequately trained in:

- awareness of the hazards involved,
- how to adopt necessary precautions according to GMPP described above,
- how to handle broken or leaking containers to prevent exposure to biological agents, and
- how to handle spills and use disinfectants to manage any contamination.

Specimens must be observed on receipt to make sure they have been packaged correctly according to shipping requirements and that they are intact. Where breaches of packaging are observed, the package should be placed in an appropriate sealable container. This surface of the container should then be decontaminated and transferred to an appropriate location such as a BSC before opening. The breach in packaging should be reported to the sender and couriers.

Specimen request or specification forms must be placed separately, preferably in waterproof envelopes, away from potential damage or contamination. Laboratories that receive large numbers of specimens should consider designating a room or area specifically for receiving specimens.

### 3.4.2 Storing specimens

Specimens must be stored in containers that are:

- made of adequate strength, integrity and volume to contain the specimen,
- leak-proof when the cap or stopper is correctly applied,
- made of plastic (whenever possible),
- free of any biological material on the outside of the packaging,
- correctly labelled, marked and recorded to facilitate identification, and
- made of an appropriate material for the type of storage required.

Care must be taken when storing specimens in liquid/vapour phase nitrogen. Only tubes specifically noted by the manufacturer as being suitable for liquid nitrogen cryogenic storage should be used to reduce the likelihood of breakage on removal from liquid nitrogen. It is important to note that liquid and vapour can enter improperly sealed or cracked tubes and can rapidly expand on removal of the tube from storage; this can lead to breakage and/or explosion. Thermal protective gloves and apron should be worn when accessing liquid nitrogen storage and a visor should be worn for splash protection.

### 3.4.3 Inactivating specimens

Inactivation methods must be appropriately validated whenever an inactivation step is used upon receipt of specimens or before transferring the specimens to other areas for further manipulation, such as PCR analysis. More information on inactivation can be found in *Monograph: decontamination and waste management (22)*.

## 3.5 Decontamination and waste management

Any surface or material known to be, or could potentially be, contaminated by biological agents during laboratory operations must be correctly managed to control biological risks. Core biosafety requirements for the handling of contaminated waste material require that processes for the identification and segregation of contaminated materials be adopted before decontamination and/or disposal. Where decontamination cannot be performed in the laboratory area or onsite, the contaminated waste must be packaged in an approved (that is leak-proof) manner for transfer to another facility with decontamination capacity. For more information on this process, please refer to section 6 transfer and transport.

A summary of different categories for segregating laboratory waste and their recommended treatment is given in Table 3.2.

**Table 3.2** Categories of segregated laboratory waste materials and their recommended treatment

CATEGORY OF LABORATORY WASTE MATERIAL	TREATMENT
Uncontaminated (non-infectious) material	Can be reused or recycled or disposed of as general municipal waste
Contaminated sharps (hypodermic needles, scalpels, knives and broken glass)	Must be collected in puncture-proof containers fitted with covers and treated as infectious
Contaminated material for reuse or recycling	Must be first decontaminated (chemically or physically) and then washed; thereafter it can be treated as uncontaminated (non-infectious) material
Contaminated material for disposal	Must be decontaminated onsite OR stored safely before transportation to another site for decontamination and disposal
Contaminated material for incineration	Must be incinerated onsite OR stored safely before transportation to another site for incineration
Liquid waste (including potentially contaminated liquids) for disposal in the sanitary sewer system	Should be decontaminated before disposal in the sanitary sewer

The eventual treatment of the segregated waste will depend on the type of material, the biological agent(s) being handled, locally available decontamination methods and locally available protocols for decontamination. Additional consideration of non-biological hazards, for example, chemicals or sharps, may be required to ensure that risk control measures are in place to minimize these non-biological risks.

Where decontamination treatments are applied to surfaces and/or materials, the method must have been validated for the specific biological agents used and must be compatible with the materials and equipment being treated to avoid corrosion or damage. Proof of efficacy and efficiency of the method should be able to be produced to validate that the contaminated waste has been effectively decontaminated.

The following subsections describe some of the most common methods of decontamination used by laboratories and the core requirements to ensure their effective use to control biological risks. They include both chemical and physical decontamination methods. Detailed information can be found in *Monograph: decontamination and waste management (22)*.



### 3.5.1 Chemical disinfection

Chemical disinfection is a method of decontamination that involves the application of a chemical, or mixture of chemicals, to an inanimate surface or material to inactivate viable biological agents or reduce their number to a safe level. Disinfectants are usually the preferred method for decontamination of surfaces; however, this is generally not required for regular cleaning of floors, walls, equipment and furniture as a core requirement for biosafety. Disinfectants should be used after a spill, or where contamination is known or suspected to have occurred. Disinfection of surfaces (and materials where applicable) should also be performed after work has been completed on the bench and periodically as part of a cleaning regime. Disinfectants can also be used for decontamination of contaminated liquids.

As there is an ever-increasing number and variety of commercial disinfectant products, formulations must be carefully selected for the specific needs of the laboratory based on the effectiveness of decontamination and compatibility with the equipment and materials.

Heavily soiled material may require pre-cleaning (that is the removal of dirt, organic matter and stains) before decontamination as many disinfectants claim to be active only on pre-cleaned items. Pre-cleaning must be performed with care to avoid exposure to and further spread of biological agents.

In choosing the disinfectant, three important factors must be considered for optimum effectiveness against biological risks:

- spectrum of laboratory activity (with high specificity for the biological agents to be disinfected),
- field of application (for example, application in liquids or on surfaces), and
- application conditions (contact time, concentration of the disinfectant, temperature of the application and other important influencing factors such as the presence of an organic load, for example, serum or blood).

Non-biological hazards posed by chemical disinfectants should also be considered and appropriate non-biological risk control measures applied. For example, many chemical disinfectants may be harmful to humans, animals and/or the environment or pose a fire or explosion risk. For this reason, chemical disinfectants must be selected, stored, handled, used and disposed of with care, following manufacturers' instructions. Particular care is needed in the use and storage of such chemicals in tropical regions where their shelf life may be reduced because of high ambient temperatures and exposure to sunlight. PPE should be used to reduce the likelihood of exposure of personnel to both the chemical hazard and any biological agents present. Specific guidance on PPE requirements can be found in safety data sheets (also called material safety data sheets) provided by the manufacturer. Detailed information on the use of chemical disinfectants can be found in *Monograph: decontamination and waste management (22)*.

### 3.5.2 Autoclaving

Autoclaving, when used correctly, is the most effective and reliable means to sterilize laboratory materials and decontaminate waste materials by destroying or inactivating biological agents.

Autoclaving uses high temperatures (for example, 121 °C, 134 °C) applied as moist heat (steam) under pressure to destroy microorganisms. Achieving sufficiently high temperature is required because, although most infectious biological agents are destroyed by heating at 100 °C, some are heat-resistant (such as spores) that cannot be destroyed at this temperature. Autoclaving allows a higher temperature and pressure to be achieved and maintained for a period of time that is sufficient for spore inactivation.

Different types of waste materials generally require different operating cycles to achieve appropriate inactivation temperatures. Therefore, laboratory autoclaves should be selected based on defined criteria such as intended use, and type and amount of waste to be decontaminated. Their effectiveness for the specific cycles that will be used should then be validated.

The main component of an autoclave is a pressure vessel (or sterilization chamber), which can be sealed tightly by a lid or a door. An arrangement of pipes and valves allows steam to be introduced and removed.

In simple devices (Figure 3.1), the lower part of the vessel is filled with water, which can then be evaporated by an electric heater. Steam produced at the beginning of the process displaces air in the chamber, which exits through an exhaust valve.

The holding time, temperature and pressure used for the autoclave cycle help determine the efficiency of inactivation. Autoclaves must therefore be equipped with systems to check these parameters. A written log should be maintained to record, for each cycle performed, the time, date, operator name, and type and approximate amount of waste that was treated.

Since air is an efficient insulator, it is essential that air is effectively removed from the chamber in order to ensure temperatures are not affected. Air displacement and removal can be supported and accelerated by a prevacuum process with repeated steam injection and evacuation steps. This is particularly important in the case of porous loads, from which it is difficult to displace the air. It is essential that the material is packed in an air- and vapour-permeable way to allow complete removal of the air. Air pockets trapped inside the goods prevent proper steam contact, lead to cold spots and may prevent complete inactivation of biological agents. The criteria for loading the autoclave chamber must therefore be precisely defined so that complete air evacuation and steam penetration are always guaranteed, even under worst-case conditions.

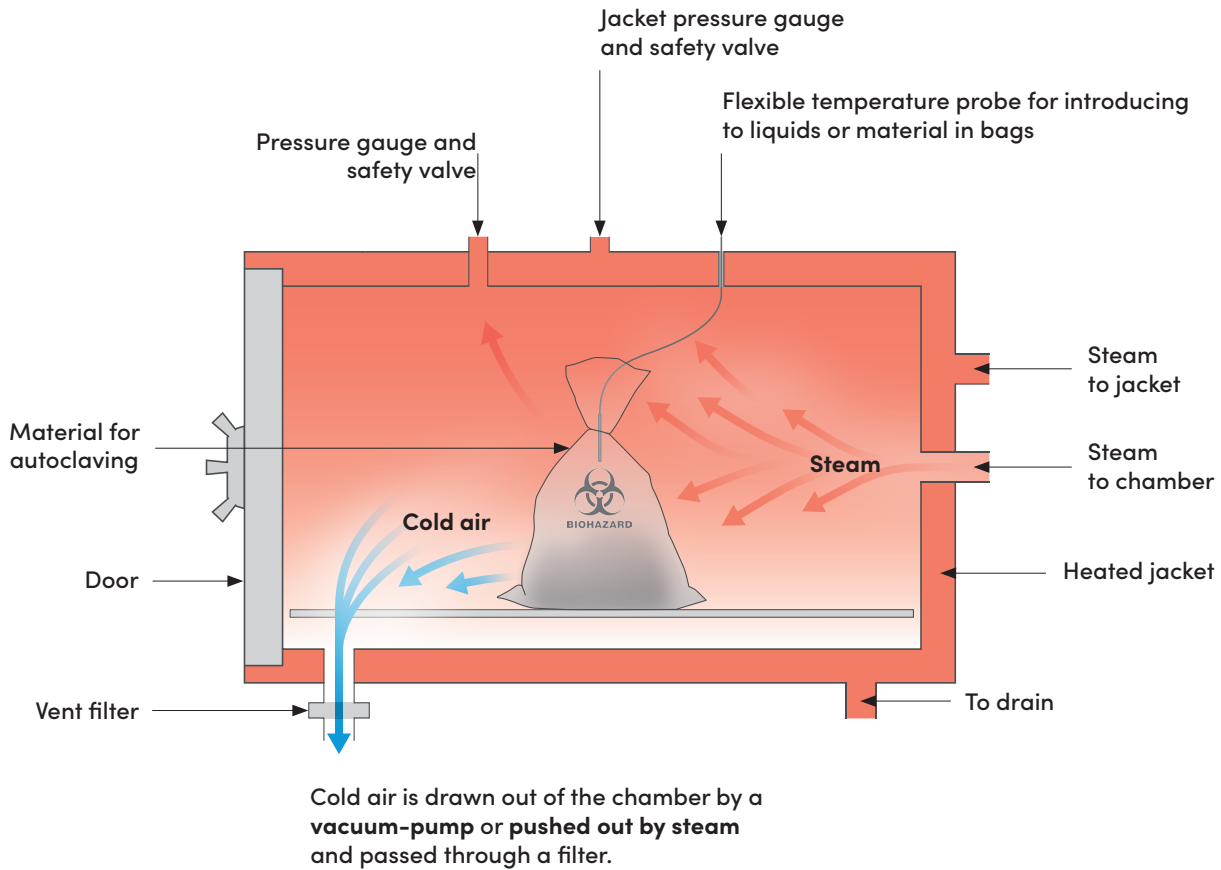

### Autoclave operation

There are autoclave cycles operating with a vacuum (active) or without vacuum (passive).

**Active (vacuum pump):** the chamber is subjected to successive pressure changes to draw air from the chamber (vacuum-steam) through a vent filter (based on a risk assessment). This is required for loads such as waste bags, glassware and other equipment where trapped air cannot reliably be removed by passive methods. The more difficult air is to remove, the more pressure pulses will be required.

**Passive:** steam enters the chamber and cold air is pushed out by the steam. This is the simpler method, but is only suitable for loads which do not impede the removal of air from the chamber.

**Figure 3.1** Simple laboratory autoclave

The proper inactivation of contaminated waste must be regularly checked. In addition to temperature, pressure and time monitored by the autoclave, biological indicators should also be used periodically to prove inactivation. Because of its heat-resistant characteristics, spores of *Geobacillus sterothermophilus* are most often used for efficiency testing. These biological indicators are designed to demonstrate that an autoclave is capable of destroying microorganisms. Alternatively, the biological agents used in the laboratory can also serve as biological indicators for waste inactivation.

There are also different classes of chemical indicators available, from simple indicators to multiparameter indicators, which provide more accurate checks of time and temperature. These test strips usually show a characteristic and recognizable colour change, but this does not necessarily prove that the waste has been completely inactivated. It only indicates that the product has undergone certain treatment conditions defined by the manufacturer. A simple chemical indicator or autoclave tape can be used as a visual control to avoid confusion between treated and untreated material. However, these indicators do not provide any information on how long a certain temperature has been maintained or whether inactivation was successful. More information on the types and use of indicators for the performance testing of an autoclave, can be found in *Monograph: decontamination and waste management* (22).

The following general safety precautions must be taken when using steam autoclaves.

- Operation and maintenance of autoclaves must be assigned to trained, competent individuals.
- Operating instructions for the autoclave must be available. Sterilization programmes with application area (for example, solids, liquids) and the parameters to be maintained (temperature, pressure, time) must be defined.
- A loading plan (with information on the contents, number, volume and mass of the sterilized product) should also be available. Large and bulky material, large animal carcasses, sealed heat-resistant containers and other waste that impedes the transfer of heat must be avoided.
- A preventive maintenance programme must be developed, including regular visual inspection of the chamber, door seals, gauges and controls. This should be conducted by qualified personnel.
- A reliable steam source must be used to provide appropriately saturated steam, uncontaminated by water droplets or chemicals which inhibit the function of the autoclave, or may damage the pipes or chamber of the autoclave.
- Waste or materials placed in the autoclave must be in containers that readily allow removal of air and permit good heat penetration.
- The chamber of the autoclave must be loosely packed so that steam can penetrate evenly.
- Hazardous chemical waste (for example, bleach), mercury or radioactive waste must not be treated in an autoclave.
- Operators must wear suitable thermally protective gloves, protective clothing and eye protection when opening the autoclave, even when the temperature has fallen to levels appropriate for opening the chamber.

- Care should be taken to ensure that the relief valves and drains of autoclaves do not become blocked by paper, plastic or other materials included in the waste or materials for decontamination.
- For the decontamination of volatile hazardous material (for example, spores of pathogens) the air relief of the autoclave must be equipped with an appropriate filter.

More information on the various types of autoclave and their validation, maintenance and specifications can be found in *Monograph: decontamination and waste management (22)*.

### 3.5.3 Incineration

Alternative methods of decontamination can be used if disinfection cannot be achieved or validated because of the large size or increased bioburden of the contaminated materials. A commonly used inactivation method is incineration, which also acts as a disposal mechanism, including for animal carcasses.

Use of incineration must meet with the approval of local public health and air pollution authorities. Incinerators must be appropriate for use with the material being incinerated; for example, one normally used for the incineration of paper is not suitable for laboratory waste. A complete burn must be achieved, that is complete to ash.

This is particularly important if burn pits are being used, for example, in an emergency, to avoid the potential for infection. Emission of decomposition odours and attraction of vermin defeats the purpose of the exercise.

## 3.6 Personal protective equipment

PPE refers to a set of wearable equipment and/or clothing worn (for example, gloves) by personnel to provide an additional barrier between them and the biological agents being handled, which effectively controls risk by reducing the likelihood of exposure to the agents. A selection of the most common PPE that must be used as a core requirement for biosafety are described in the following subsections.

Any PPE used in the laboratory must be correctly fitted, and personnel must be given adequate training in order to ensure it is used properly and effectively. Incorrect use of PPE, for example, unfastened laboratory coats, will not give the protection they are designed to provide. When combinations of PPE are worn together, they must complement one another and continue to fit properly.

It is important to note that there is not one size, type and/or brand that is appropriate for all personnel. Laboratory personnel should be consulted and a selection of items tested in order to procure the most effective items. Compliance with wearing PPE will generally be improved when users have input on comfort and fit.

Detailed information on selection, validation, fit testing and other considerations for PPE can be found in *Monograph: personal protective equipment (20)*.

### 3.6.1 Laboratory coats

Laboratory coats must be used in laboratories to prevent personal clothing from getting splashed or contaminated by biological agents. Laboratory coats must have long sleeves, preferably with fitted cuffs, and must be worn closed. Sleeves should never be rolled up. Coats must be long enough to cover the knees, but not trail on the floor.

Where possible, the fabric of the laboratory coat should be splash-resistant and overlap at the front. Laboratory coats can be reusable or disposable, although where reusable coats are used laundering of the coats must be done by the laboratory or specialist contractor. Laundering must be done regularly, and consideration should be given to autoclaving any visibly contaminated coats before laundering.

Laboratory coats must only be worn in designated areas. When not in use, they should be stored appropriately; they should not be hung on top of other laboratory coats, or in lockers or hooks with personal items. Laboratory coats should not be taken home by personnel.

### 3.6.2 Footwear

Footwear must be worn in the laboratory and must be of a design that minimizes slips and trips and can reduce the likelihood of injury from falling objects and exposure to biological agents. Footwear should cover the top of the foot, and should be well-fitting and comfortable to allow personnel to perform their tasks without fatigue or distraction.

### 3.6.3 Gloves

Appropriate disposable gloves must be worn for all procedures that may involve planned or inadvertent contact with blood, body fluids and other potentially infectious materials. They must not be disinfected or reused as exposure to disinfectants and prolonged wear will reduce the integrity of the glove and decrease protection to the user. Gloves should always be inspected before use to check they are intact.

Different types of gloves may be needed for different applications or other occupational hazards, such as thermal protection, or protection from sharps or against chemicals. Various sizes should be available to ensure that gloves properly fit the user to allow adequate movement and dexterity for the procedures being performed. Nitrile, vinyl and latex gloves are often used for protection against biological agents. It should be noted that latex protein could cause allergy over time; low protein and powder-free options are available to minimize the occurrence of an allergy.

### 3.6.4 Eye protection

Safety glasses, safety goggles, face shields (visors) or other protective devices must be worn whenever it is necessary to protect the eyes and face from splashes, impacting objects and artificial ultraviolet radiation. Eye protection must be cleaned after every use. If splashed, it must be decontaminated with an appropriate disinfectant.

Personal prescription glasses (spectacles) must not be used as a form of eye protection as they do not cover enough of the face around the eyes, particularly around the side of the head. Specialized prescription safety glasses must be purchased for personnel with such needs. Some goggles are available that have recesses that enable the user to wear glasses underneath them.

### 3.6.5 Respiratory protection

Respiratory protection is generally not required for protection against biological agents as a part of the core requirements. Where a risk assessment indicates that the use of respiratory protection is needed, this is considered a heightened control measure. However, there may be circumstances where respiratory protection is required for other reasons based on assessments for non-biological hazards such as chemicals or allergens.

## 3.7 Laboratory equipment

When used effectively together with GMPP, the safe use of laboratory equipment will help minimize the likelihood of exposure of personnel when handling or manipulating biological agents.

For equipment to effectively reduce risks, laboratory management must make sure sufficient space is provided for its use. An appropriate budget must be available for the equipment's operation and maintenance, including equipment incorporated into the facility design, which should be accompanied by specifications that outline its safety features. All personnel operating or maintaining a piece of equipment must be properly trained and be able to demonstrate proficiency.

Records must be kept detailing equipment use, any maintenance performed, and any validation/calibration procedures undertaken and their results. Where appropriate, the following records should also be kept:

- equipment inventories (which may also include details on age, condition, functioning),
- equipment purchase requests,

- contact information of people authorized to purchase, install, calibrate, validate, certify, operate and maintain equipment,
- unscheduled maintenance or incidents, and
- training and proficiency of personnel authorized for equipment use.

Selected equipment must be designed, constructed and installed so that it facilitates simple operation and allows for maintenance, cleaning, decontamination and certification to be performed in a way that contact between the operators and biological agents is prevented or limited wherever possible. Equipment must be constructed of materials that are impermeable to liquids (including chemicals used for decontamination), resistant to corrosion and that meet the structural requirements of the required tasks. It should be built free of sharp edges and unguarded moving parts to prevent occupational hazards to personnel. Large laboratory equipment must be placed so that the workflow of laboratory personnel, specimens and waste is unobstructed. It must also be placed so that its performance will be unaffected; for example, autoclaves must be located in a well-ventilated area because of their inherent heat production. Frequently used laboratory equipment such as incubators, refrigerators, freezers and centrifuges must be located ergonomically for laboratory personnel so it is easily accessible to avoid over-reaching and/or to allow work to proceed without overcrowding, which can increase the risk of musculoskeletal injury.

Equipment must be judged fit for purpose before use, which will usually be outlined in the manufacturer's instructions. Unless laboratory SOPs indicate otherwise, the manufacturer's instructions must always be followed.

All equipment must be checked regularly for integrity and to identify potential faults. Any faults must be reported immediately and corrective actions taken to rectify them before the equipment is used again. Performance verification must be done at regular intervals, in between scheduled preventive maintenance and servicing, to ensure the equipment is functioning as expected.

### 3.7.1 Specialized laboratory equipment

Best practice is required when using some of the most commonly used pieces of laboratory equipment in order to effectively reduce biological risks. These types of equipment are described in the following subsections.

#### Pipettes

To prevent the generation of aerosols, pipettes must not be used to blow air or forcibly expel liquids/solutions that contain biological agents. All pipettes and/or the pipette tips should have cotton plugs to reduce contamination of pipetting devices.



As an important part of GMPP, all personnel must be adequately trained in the correct use of pipettes to reduce risks of contamination caused by aerosolization and splashing and thus improve both safety and quality.

To avoid further dispersion of any biological agents that might be dropped from a pipette tip, an absorbent material may be placed on the working surface and disposed of as infectious waste after use. Contaminated pipettes or tips can be completely submerged in a suitable disinfectant in an unbreakable container. If chemically disinfected, they should be left in the disinfectant for the appropriate length of time before disposal or washing. Pipette tips are normally autoclaved, but pipettes are unlikely to withstand the autoclaving process.

### Centrifuges

All centrifuges must be operated and serviced according to manufacturers' instructions and serviced by appropriately qualified personnel. Where safety buckets are available for a centrifuge, these must be used. Sealing rings for buckets must be checked regularly for integrity and replaced if cracks appear.

When using centrifuges, the contents of centrifuge tubes must be filled to the same level and placed in the centrifuge at opposite locations to make sure the centrifuge is balanced during operation. Centrifuges must be cleaned and disinfected regularly, or immediately decontaminated after a spill, with an appropriate disinfectant.

### Refrigerators and freezers

Refrigerators and freezers must be spark-proof if they are to store flammable solutions. Notices to this effect must be placed on the outside of the doors. Appropriate PPE must be worn when handling specimens from cryogenic storage, for example, thermal protective apron and gloves, as well as face and eye protection when placing specimens in or removing them from liquid nitrogen. All containers stored inside refrigerators and freezers must be clearly labelled so that they can be easily identified. An inventory of their contents must be maintained and controlled periodically. Unlabelled materials must be assumed to be infectious and must be decontaminated and discarded using appropriate waste channels. Unlabelled items should also be reported as a near miss as this indicates a failure of the SOPs and risk assessment.

## 3.8 Emergency/incident response

Even when carrying out low-risk work and following all core requirements for biosafety, incidents can still occur. To reduce the likelihood of exposure to/release of a biological agent or to reduce the consequences of such incidents, a contingency plan must be developed that provides specific SOPs to be followed in possible emergency scenarios that apply to the work and local environment. Personnel must be trained on these procedures and have periodic refresher training in order to maintain competency.

Emergencies can include those related to chemical incidents, fire, electrical breakdown, radiation incidents, pest infestation, flooding, or personal health issues of personnel (for example, a heart attack or collapse). All laboratory facilities must have good safety standards for all such non-biological hazards to make sure that necessary non-biological risk control measures are also in place (for example, fire alarms, extinguishers, chemical showers). Relevant authorities should be consulted where necessary.

First-aid kits, including medical supplies such as bottled eye washes and bandages, must be available and easily accessible to personnel. These must be checked routinely to make sure products are within their use-by dates and are in sufficient supply. If eyewash stations with piped water are to be used, these should also be checked regularly for correct functioning.

All incidents must be reported to the appropriate personnel, usually a laboratory supervisor, in a timely manner. A written record of accidents and incidents must be maintained, in line with national regulations where applicable. Any incident that occurs must be reported and investigated in a timely manner. Results from incident investigations must be used to update laboratory procedures and emergency response. More information on incident reporting and investigation can be found in section 7 biosafety programme management and *Monograph: biosafety programme management (17)*.

### 3.8.1 Biological spill response

Spill kits, including disinfectant, must be easily accessible to personnel. Depending on the size, location, concentration and/or volume of the spill, different protocols may be necessary. Written procedures for cleaning and decontaminating spills must be developed for the laboratory and followed by suitably trained personnel.

If a spill occurs where there is a high initial risk (due to a large formation of aerosols, a large volume/high concentration of liquid spill, and/or high pathogenicity of the biological agent involved) the following protocol should be followed:

- Personnel must immediately vacate the affected area.
- Exposed persons should be referred immediately for medical evaluation.
- The room containing the spill should not be entered for a length of time that allows aerosols to be carried away and heavier particles to settle. If the laboratory does not have a central air exhaust system, entrance should be delayed for longer.
- Signs must be posted indicating entry is forbidden.
- The laboratory supervisor and the biosafety officer must be informed as soon as possible after the event has occurred.

- After the necessary amount of time has elapsed, decontamination must proceed; depending on the size of the spill, this may require help or supervision, for example, by the biosafety officer.
- Suitable protective clothing and respiratory protection may be needed for the spill clean-up.

More information on dealing with spills can be found in *Monograph: decontamination and waste management (22)*.

### 3.9 Occupational health

The employing authority, through the laboratory director, must take responsibility for ensuring that the health of laboratory personnel is adequately checked and reported. The objective is to provide a safe working environment including preventative measures (for example, vaccination) and monitoring of employee health to enable appropriate measures to be taken in case of exposure or occupationally related disease or any other aspect of the work that affects the safety, health and well-being of employees.

Medical examination or health status information of laboratory personnel may be required to ensure that it is safe for them to work in the laboratory. All aspects of an employee's health status must be kept confidential. Examples of activities to achieve these objectives can be found in *Monograph: biosafety programme management (17)*.



# HEIGHTENED CONTROL MEASURES

For most procedures, the core requirements will be sufficient to keep risks acceptable. However, during the risk assessment, a situation may be identified in which the initial risk requires the use of one or more heightened control measures, over and above those outlined in the core requirements, to reduce the risks to acceptable risks.

There are many different risk control measures available to address a single type of risk, and the selection of the most appropriate and effective measure will depend on local circumstances. Where national regulations exist, there may be compulsory, predefined lists of risk control measures to be used. Beyond this, the appropriateness of a risk control measure must be justified by the risk assessment; for example, a procedure identified with a high likelihood of exposure because of the use of an aerosol-generating procedure will require risk control measures that reduce the formation and/or capture of aerosols. The effectiveness of the risk control measure, or its ability to reduce the residual risk, should be determined by considering the resources available (for purchase, installation and maintenance of the risk control measure), the competency of the personnel, and the practicality of implementation.

The following subsections revisit each of the essential elements of laboratory operation described in section 3 core requirements. They outline additional procedures, features, risk control measures, equipment and considerations that may be needed in these areas, over and above the core requirements. It should be noted, however, that unlike the core requirements, the risk control measures and considerations for each element may not apply to every laboratory, and their use should be carefully selected based on the outcomes of the local risk assessment.

## 4.1 Operational working practices and procedures

Irrespective of any additional heightened control measures applied, GMPP will always be the basis on which all work is performed. However, the following additional practices can be considered, depending on the risks identified.

- Associated protocols developed to restrict access to only trained individuals and/or specified personnel in that area.
- Special entry conditions can be applied for some personnel which are a prerequisite for entering the laboratory, for example, specific immunizations.
- Open manipulations of biological agents may need to be conducted using a primary containment device such as a BSC, and/or respiratory protection may need to be used.

## 4.2 Personnel competence and training

Additional training will be required for any procedures, biological agents, systems or equipment that require heightened control measures.

Training should include both competency in the related protocols (including any maintenance, if required) and emergency operations should an incident occur, or the risk control measure fail.

A prescribed period of mentorship is recommended when using the heightened control measure and its associated procedures until personnel are considered competent. Competence in the relevant procedure must be assessed and documented before unsupervised work proceeds. Competency must be regularly reviewed to ensure best practices are maintained.

## 4.3 Facility design

In some cases, the laboratory facility will need to accommodate additional in-built heightened control measures (engineering controls) and/or be designed in a way that enables the incorporation of heightened control measures and facilitates their safe operation and associated protocols. Heightened control measures associated with facility design can include, based on the outcome of the risk assessment, the following:

- Physically separating the laboratory room/spaces from areas open to unrestricted traffic flow within the building, thus reducing the risk of exposure to passing individuals not directly involved in the laboratory work.
- Physical separation between the laboratory and the surrounding building can be achieved by use of an anteroom or by siting the laboratory at the end of a corridor. In some cases a separate building will be part of heightened control measures.
- Closing and sealing windows.
- Where gaseous disinfection is selected as a heightened control measure for decontamination and waste management, laboratory room/space airtightness will need to be enhanced. This is achieved by sealing all surfaces and/or laboratory penetrations to prevent the escape of hazardous gases.
- Configuring laboratory exhaust airstream to discharge in a way that reduces the likelihood of exposure of any people, animals and/or the outside environment to the exhaust air, for example, discharging exhausts away from air intake vents. Alternatively (or additionally), exhaust air can be filtered before exhausting.
- Installing space for the onsite treatment of laboratory waste, or by providing dedicated secure storage for laboratory waste until it can be transported off-site for decontamination.

Additional laboratory facility design criteria may be needed to accommodate risk control measures that address biosecurity risks. For these measures, please refer to *Monograph: laboratory design and maintenance (21)*.

#### 4.4 Specimen receipt and storage

Heightened control measures that may be required for specimen receipt and storage include the following:

- Opening specimens (from their transfer or transport containers) within a primary containment device and/or while wearing additional PPE.
- Applying more stringent restricted-access protocols to storage areas.
- Developing additional internal transfer and transport mechanisms.

#### 4.5 Decontamination and waste management

Waste generated by procedures using heightened control measures should preferably be decontaminated onsite, or close to the laboratory, to minimize the risk of exposure or release during waste transportation.

Where onsite decontamination is not possible, solid waste must be appropriately packaged, stored (if required) and transferred as soon as possible to another facility with decontamination capabilities. Infectious waste must first comply with any applicable transportation regulations if it is to be removed from the laboratory for decontamination and disposal. Consideration should be given to transporting waste in sealed and leak-proof containers.

Detailed information on waste management can be found in *Monograph: decontamination and waste management (22)*. For more information on the transport of infectious substances, please refer to section 6 transfer and transportation.

#### 4.6 Personal protective equipment

Heightened control measures may include specialized PPE and/or specialized protocols with core requirement PPE that help further reduce identified risks.

### 4.6.1 Laboratory coats/clothing

Laboratory coats are worn as part of core requirements; however, the following additions should be considered:

- Laboratory coats that overlap at the front can be worn to provide extra protection against splashes and spills.
- Alternative protective clothing such as gowns, scrubs and coveralls can be used.
- An additional fluid-resistant apron, laboratory coat and/or disposable sleeves can be worn for procedures where the possibility of large splashes cannot be discounted.
- Reusable items can undergo an appropriate decontamination procedure (such as autoclaving) before laundering.
- Scrubs or other dedicated laboratory protective clothing can be worn to prevent contamination of personal clothing.

### 4.6.2 Footwear

Footwear may need to be changed and/or covered before entry into the laboratory if there is a requirement to prevent cross contamination.

### 4.6.3 Gloves

Additional gloves (for example, double gloving, insulated gloves for handling very hot or very cold items, bite-resistant gloves for animal work or chemical-resistant gloves for working with certain hazardous chemical) may be required for some activities. This may include animal work, work with concentrated waste liquid material or where a two-step decontamination process is used.

An appropriate range of sizes must be available to ensure proper fitting of the multiple layers. It is important to note that wearing several layers of gloves can reduce dexterity, thereby potentially increasing the likelihood of exposure by not being able to handle specimens appropriately. This must be considered during the risk assessment process and incorporated into training.

### 4.6.4 Eye protection

Eye protection is required in the same circumstances as outlined in the core requirements. However, these items need to be compatible with respiratory protection, if worn.



### 4.6.5 Respiratory protection

Respiratory protective equipment is a form of PPE designed to protect the wearer from inhaling particles that contain biological agents and/or other respiratory hazards that may be present in ambient air. Respiratory protection can be used to protect personnel from aerosols as an alternative or in addition to performing work in a BSC. However, this should only be done with careful consideration of the risks it is being used to address as this equipment only protects the wearer. Therefore, other measures may be required to ensure that any other laboratory personnel and/or the local environment at risk of exposure are also protected.

Various types and classes of respiratory protective equipment are available and the choice will depend on the work being carried out and the laboratory personnel who may have to wear this equipment (see subsections below). It is important that the respiratory protective equipment is selected carefully according to the results of a risk assessment. It must only be used by trained personnel to ensure that it is suitable and used correctly. When using respiratory protective equipment, consideration must be given to the following factors.

- Its level of protection must be appropriate for the risks identified and its use must adequately reduce exposure (by filtering infectious particles) to the level required to protect the wearer's health.
- The wearer must be able to work freely and without additional risks while wearing the respiratory protective equipment.
- It must be worn correctly and according to the manufacturer's instructions.
- It must fit and be suitable for the person wearing it, which may require procuring different types and brands of respiratory protective equipment for different laboratory personnel and/or procedures.
- When reusable respiratory protective equipment is used, it must be appropriately decontaminated after use, and properly stored and maintained.
- It must complement any other PPE being worn. This is especially important in the use of eye protection.

#### Respirators

Respirators are filtering devices that remove contaminants from the air being breathed in. It is important to note that for a respirator to offer protection against aerosolized biological agents, it needs to have a particulate filter; respirators with gas filters will not necessarily protect against biological agents.

Different respirators offer different levels of protection. The assigned protection factor is a number rating that indicates how much protection a respirator provides. For example, a respirator with an assigned protection factor of 10 will reduce the wearer's exposure by at least a factor of 10, if used properly.

Assigned protection factors depend on the respirator type and the efficiency of the filtering material and fit. They can differ between countries depending upon how they are tested.

Fit testing is the term given to the method of checking that a facepiece matches the wearer's facial features. As many respirators rely on having an effective seal between the facepiece and the wearer's face, fit testing must be done whenever possible. Fit testing can include verifying that the respirator seals adequately to the user's face using quantitative particle counting devices or qualitative sprays of bitter and sweet chemicals. It also helps to identify unsuitable facepieces that should not be used.

If the respirator does not fit correctly, it will not provide the required level of protection for the wearer. Respirators must be checked over time to ensure that multiple use has not impaired the fitting to the face because of loss of shape and/or clogging of the filters. Respirators will only provide effective protection if the wearer is free of jewellery in the area of the face seal. Alternative designs of respiratory protective equipment can be provided that do not rely on a face seal. However, they will require the use of an air supply to provide a positive pressure and be more expensive to purchase and maintain. More information on fit testing can be found in *Monograph: personal protective equipment (20)*.

### Surgical masks

The main intended use of surgical masks is to protect patients and clinical areas from biological agents present in the nose and mouth of the person wearing the mask. When worn to protect the wearer, they provide limited splash and droplet protection. As such, surgical masks are not classified as respiratory protective equipment. The use of proper respiratory protective equipment should be considered, if the risk assessment so dictates.

Further information on respirators and other forms of respiratory protective equipment can be found in *Monograph: personal protective equipment (20)*.

## 4.7 Laboratory equipment

Special consideration may need to be given to the equipment being used during higher risk procedures. These include:

- applying additional containment accessories to current equipment, for example, safety buckets or containment rotors in centrifuges,

- dedicating current equipment for use only for the higher-risk tasks to avoid cross contamination, and
- using additional, dedicated safety equipment to protect against infectious aerosols.

The most commonly used equipment for controlling any higher aerosol risks is a primary containment device, such as a BSC. In addition to reducing exposure to aerosols, these can also act to isolate higher-risk, aerosol-generating work or equipment from other areas of the laboratory.

Several different types of BSC exist. There are also other non-standard designs of primary containment device which have come into use for a number of reasons, including cost, portability and requirement for a customized design. Table 4.1 provides a basic overview of some of the common types of primary containment devices. More information on the types, functions and uses of BSCs and other containment equipment can be found in *Monograph: biological safety cabinets and other primary containment devices (19)*.

## 4.8 Emergency/incident response

The following may need to be considered where there are higher risks of an incident or exposure to biological agents.

- Planning for and sourcing of post-exposure prophylaxis and therapeutics that may be necessary.
- An emergency shower. Although this is primarily to deal with exposure to chemical hazards, it can be used to help disinfect personnel who may have been exposed to a large volume of biological agent, for example, during animal handling.
- Supervision of laboratory work outside of normal working hours. Approaches include a buddy system or special devices that can be used to alert specified personnel (such as security) if the device detects that the operator has fallen or remained motionless for a set period of time.

## 4.9 Occupational health

In addition to the measures outlined in the core requirements, the following heightened control measures may be required to ensure employee health and safety.

Medical examination of all laboratory personnel who work with heightened control measures to determine their health status is not at risk in performing the work. This should include a detailed medical history and an occupationally-targeted examination, which should be recorded.

- Provision by the physician of a medical contact card with a medically cleared emergency point of contact in case a sudden illness occurs outside of work hours.

**Table 4.1** Types and features of primary containment devices

TYPE OF PRIMARY CONTAINMENT DEVICE	KEY FEATURES
Class I BSCs	<ul style="list-style-type: none"> <li>▪ Open-fronted cabinets with an inward airflow designed to protect the operator and the environment from infectious aerosols generated.</li> <li>▪ Simple airflow design allows performance maintenance in most laboratory situations. If specified with higher inflow rates, they may perform better than other BSC types in certain circumstances.</li> <li>▪ The air discharged can be passed through an appropriate filter (for example, a HEPA filter) before being discharged or recirculated into the laboratory.</li> </ul>
Class II BSCs	<ul style="list-style-type: none"> <li>▪ Several different Class II BSCs exist, each of which has slightly different airflow arrangements and/or mechanisms. A brief overview of these can be found in <i>Monograph: biological safety cabinets and other primary containment devices</i>.</li> <li>▪ One of the most commonly used BSCs in laboratory facilities is the Class II type A2 or an equivalent European standard type (CEN 12469). These open-fronted cabinets have a complex airflow pattern, which mixes inflow air with internally filtered downflow air. This provides protection to work surface materials, for example, cell cultures, in addition to users and the environment.</li> <li>▪ The complex airflow of Class II BSCs means their performance can easily be affected by factors such as cabinet positioning, room ventilation rates and pressure differences. For this reason, Class I BSCs may be a more sustainable choice because of their simpler design and the robustness of their protection to the operator when product protection is not a major consideration.</li> <li>▪ Air from the workspace is passed through an appropriate filter before discharge. This air can be recirculated to the room, discharged to the outside of the building through a thimble duct/canopy hood connection to a dedicated duct, or discharged through the building's heating, ventilation, and air conditioning exhaust system.</li> </ul>

BSC = biological safety cabinet; HEPA = high efficiency particulate air.

**Table 4.1** Types and features of primary containment devices (continued)

TYPE OF PRIMARY CONTAINMENT DEVICE	KEY FEATURES
Class III BSCs	<ul style="list-style-type: none"> <li>▪ The Class III BSC is a closed-fronted design that provides complete separation between the material being handled and the operator/environment. Access to the work-surface is by means of strong rubber gloves attached to ports in the cabinet.</li> <li>▪ Class III cabinets are airtight and both supply and exhaust air are filtered (with HEPA filter or equivalent) and high rates of air change are maintained within the cabinet. Airflow is maintained by a dedicated exhaust system outside the cabinet, which keeps the cabinet interior under negative pressure compared to the surrounding space.</li> <li>▪ Additional features, such as pass boxes, dunk tanks or autoclaves, can be used to bring material into the cabinet, and/or to decontaminate it before bringing it out of the cabinet after use.</li> </ul>
Isolators	<ul style="list-style-type: none"> <li>▪ The negative-pressure, flexible-film isolator is a self-contained primary containment device that provides a high degree of user protection against hazardous biological materials. Their flexibility and customized design means isolators can be fit for purpose. They are often used to house infected animals. Solid-wall isolator systems are also widely used, although they are more affected by pressure changes.</li> <li>▪ The workspace is totally enclosed in a transparent envelope suspended from a framework. Access to the workspace may be through integrated sleeve-type gloves or an internal "half-suit", both accessed externally. The isolator is maintained at an internal pressure lower than atmospheric pressure.</li> <li>▪ Inlet air is passed through one filter and outlet air is passed through one or two filters, thus avoiding the need to duct exhaust air outside the building.</li> <li>▪ Effective pressure monitors are required to ensure correct operation. Pass boxes, dunk tanks or rapid transfer ports can also be used for the introduction, removal and decontamination of work materials.</li> </ul>
Local exhaust ventilation	<ul style="list-style-type: none"> <li>▪ For some operations, a ventilated workstation will be adequate to control any aerosols generated by a procedure. This can be constructed by connecting an open-fronted box to a HEPA filter attached to a fan to provide an internal airflow. However, unless specifically designed for biological containment work, the performance may not be as effective as BSCs.</li> </ul>

BSC = biological safety cabinet; HEPA = high efficiency particulate air.



# MAXIMUM CONTAINMENT MEASURES

Most laboratory work will be undertaken using the core requirements, or with heightened control measures. However, in exceptional circumstances, the risk assessment may necessitate the use of a facility that employs maximum containment measures to control very high risks to personnel and the community. Such a facility will only be required where biological agents with the very highest consequences are used in work that has a high likelihood of exposure. This includes work with biological agents that pose a severe health risk to personnel or the community if released, such as those that are highly transmissible and cause disease for which countermeasures are not available, or those with evidence of pandemic potential.

Laboratories using maximum containment measures, which have previously been described as biosafety level 4 (BSL4/P4) containment laboratories (3), are those that offer the highest level of protection to laboratory personnel, the community and the environment. There are few such laboratories in the world as they are very expensive to build, operate and maintain, and are not required for most work. Normally, such laboratories must comply with highly detailed national legislation and guidance, even before being given permission to operate, and they may be subject to numerous regulatory inspections on a regular basis. This section gives only a basic introduction to such facilities. More information can be found in *Monograph: laboratory design and maintenance* (21). However, the complexity and variability of such laboratories cannot readily be detailed in a single guidance document. Relevant national guidance documents can be consulted, if available.

Two laboratory designs can be used for laboratories employing maximum containment measures. The first is a cabinet line facility, where all work is carried out in a closed system of class III BSCs, within a negative-pressure laboratory. The second is a facility where operators work in positive-pressure encapsulating suits in open-fronted BSCs, also in a negative-pressure laboratory.

## 5.1 Operational working practices and procedures

The practices and procedures described in the core requirements and/or heightened control measures should also be applied for maximum containment measures with the following additional requirements:

- A complete change of clothing and shoes is required before entering and on leaving the laboratory.
- Personnel must be trained in emergency extraction procedures in the event of personnel injury or illness.
- Working alone is not permitted.
- A method of communication for routine and emergency contacts must be established between personnel working in the maximum containment measures laboratory and support personnel outside the laboratory.
- A method to visually monitor and record the activities of personnel working inside the laboratory must be implemented.

## 5.2 Personnel competence and training

Due to the initial risks of working with high-consequence biological agents in such a facility, only highly trained, specialist laboratory personnel should be allowed to work with maximum containment measures. Personnel must have an appropriate level of laboratory experience, and a specialized, in-depth, pre-service training programme must be in place. Strict supervision and mentoring must be observed until new personnel are considered suitably competent, or existing personnel considered appropriately proficient in any new processes and procedures introduced. Training should include scenario-based emergency response and periodic refresher training.

## 5.3 Facility design

The design features of a laboratory using maximum containment measures include an efficient primary containment system (Table 5.1), specific entry and access features (Table 5.2) and a dedicated heating, ventilation and air conditioning system (Table 5.3); which features are applied or not depends on the risk assessment.

It is also recommended that a laboratory using maximum containment measures be located in a separate building or, as a minimum, in a clearly delineated zone within a secure building.



**Table 5.1** Features of primary containment arrangements in laboratories with maximum containment measures

CLASS III CABINET LINE OR NEGATIVE-PRESSURE ISOLATOR LABORATORY	SUIT LABORATORY
<ul style="list-style-type: none"> <li>▪ This has a completely closed cabinet barrier system working under negative pressure that isolates the biological material from the surrounding laboratory environment.</li> <li>▪ Cabinet/isolator is equipped with filters for inlet and exhaust air, entry ports such as double-door autoclave, fumigation chambers, and/or dunk tanks.</li> <li>▪ More information can be found in <i>Monograph: biological safety cabinets and other primary containment devices</i>.</li> </ul>	<ul style="list-style-type: none"> <li>▪ This requires a number of positive-pressure suits supplied with external breathing air, which forms the barrier between the operator and the biological material.</li> <li>▪ Work is carried out in a Class I or II BSC. Primary containment devices can be used for small animals; however, if this is not possible (for example, if large animals are used), the laboratory must form the primary containment.</li> <li>▪ More information can be found in <i>Monograph: laboratory design and maintenance</i>.</li> </ul>
<p>The laboratory must be capable of undertaking gaseous decontamination (for example, fumigation) in order to allow for regular service and maintenance of the laboratory and any specialist equipment.</p>	

BSC = biological safety cabinet.

**Table 5.2** Entry and access features in laboratories with maximum containment measures laboratories

CLASS III CABINET LINE OR NEGATIVE-PRESSURE ISOLATOR LABORATORY	SUIT LABORATORY
<ul style="list-style-type: none"> <li>▪ On entering a cabinet line facility, personnel must remove all personal clothing and put on dedicated laboratory clothing (for example, scrubs, coveralls), and also dedicated PPE.</li> </ul>	<ul style="list-style-type: none"> <li>▪ All personal clothing must be removed before putting on dedicated laboratory clothing (such as scrubs) and the positive pressure suit.</li> <li>▪ The operator usually enters the laboratory through a chemical shower cubicle, which will serve to decontaminate the operator's suit upon exit.</li> </ul>
<p>Entry and exit of personnel and supplies must be through an airlock or pass-through system. Entry ports such as dunk tanks containing a validated disinfectant, pass boxes with interlocked doors and a disinfection system, or fumigation chambers must be provided for the transfer of specimens, materials or animals into or out of the primary containment laboratory. Personnel should shower before putting their own clothes back on and leaving.</p>	

PPE = personal protective equipment.

**Table 5.3** Heating, ventilation and air conditioning arrangements in laboratories with maximum containment measures

CLASS III CABINET LINE OR NEGATIVE-PRESSURE ISOLATOR LABORATORY	SUIT LABORATORY
<ul style="list-style-type: none"> <li>▪ Dedicated, room air supply and exhaust systems must be in place and constantly monitored by a building management system or equivalent.</li> <li>▪ The supply air to the laboratory facility (including Class III BSCs or negative-pressure isolators) should be designed to prevent release of biological agents because of potential backflow of air.</li> <li>▪ Exhaust air from the Class III BSC or negative-pressure isolator must be passed through two independent HEPA filters in series before release outdoors. The second filter can therefore act as a back-up in case the primary filter fails.</li> <li>▪ The cabinet or isolator must be operated at negative pressure to the surrounding laboratory at all times. Appropriate alarms should inform the laboratory personnel in case of system failures.</li> </ul>	<ul style="list-style-type: none"> <li>▪ Dedicated room air supply and exhaust systems should be in place and constantly monitored by a building management system or equivalent.</li> <li>▪ The ventilation systems must be designed to maintain controlled pressure differentials. Appropriate controls must be used to prevent pressurization of the laboratory and ensure that the facility remains under negative pressure.</li> <li>▪ Pressure differences within the suit laboratory and between the suit laboratory and adjacent areas must be monitored.</li> <li>▪ Clean air must be supplied when a person is in a suit and connected to air supply.</li> <li>▪ HEPA filtration of the breathing air could be necessary, depending on the system used, and must be monitored.</li> <li>▪ Before release outdoors, exhaust air from the suit laboratory must be passed through two independent HEPA filters in series. The second filter can therefore act as a back-up in case the primary filter fails.</li> </ul>
<ul style="list-style-type: none"> <li>▪ If necessary, controlled pressure differentials should be designed from the least to the most contaminated area.</li> <li>▪ Exhaust air could be recirculated within the cabinet line laboratory or suit laboratory depending on the risk assessment (for example, no animals, no hazardous chemicals).</li> <li>▪ All HEPA filters must be tested and certified at least annually. Filters that are not designed to be scanned (functional testing to determine leakage) need to be replaced at regular intervals. All decisions on intervals between testing of filters or replacement must be based on risk assessment and must be documented in SOPs. The housing of the HEPA filter should be designed to allow in-situ decontamination, before filter removal. Alternatively, the filter can be removed in a sealed, gas-tight primary container for later decontamination and/or destruction by incineration.</li> <li>▪ Emergency power and dedicated power supply line(s) must be provided for all critical safety equipment (that needs to continue to work to maintain safety).</li> <li>▪ Laboratory personnel should be informed by appropriate alarms in case of ventilation failures.</li> </ul>	

BSC = biological safety cabinet; HEPA = high efficiency particulate air; SOPs = standard operating procedures.

## 5.4 Specimen receipt and storage

Specimens leaving or arriving at the facility must be transported according to national and international regulations. Upon receipt, specimens must only be opened and handled within the laboratory by specially trained personnel. Specimens must be stored securely in dedicated refrigerators, freezers and liquid nitrogen storage, which can only be accessed by authorized personnel. A strict inventory of stocks and specimen movement must be kept.

## 5.5 Decontamination and waste management

All waste leaving the laboratory must be treated so that it is thoroughly decontaminated and presents no infectious threat. Methods for disinfection and decontamination of material leaving the laboratory must be validated each time they are used to verify their effectiveness.

All effluents from the suit area, decontamination chamber, suit shower and cabinet line (BSCs or isolators) must be decontaminated before final discharge using either heat or chemical treatment. Effluents may also require subsequent correction to a neutral pH and suitable temperature before discharge.

A double-door, pass-through autoclave must be available in the laboratory area. Other methods of decontamination must be available for equipment and items that cannot withstand steam sterilization, for example, an air lock fumigation chamber.

Containment drain(s) should only be installed if shown to be required by the risk assessment, for example, large animal facilities.

More information on best practice for decontamination can be found in *Monograph: decontamination and waste management (22)*.

## 5.6 Personal protective equipment

In a suit laboratory system, the suit must be designed to withstand contact with the equipment, chemicals and other materials used in the suit laboratory, and to allow tasks and contact with any animal species to be carried out safely. Detailed SOPs should be developed on safe use of the suit, with personnel receiving practice and training on how to implement the SOPs correctly.

An effective maintenance system needs to be in place that covers cleaning, disinfection, examination, replacement, repair and testing of the suit. The frequency of testing should be determined through the risk assessment. Before using the suit, visual checks and pressure tests of the integrity of the suit must be carried out.

## 5.7 Laboratory equipment

Only dedicated laboratory equipment should be used for the high-risk tasks requiring maximum containment measures. The equipment must be able to withstand fumigation or be able to be wrapped or moved to a gas-tight, fumigation-free zone within the laboratory during routine laboratory fumigation.

The use of sharps must be avoided wherever possible. If their use is unavoidable, specific and detailed SOPs must be developed and implemented, and extensive training in the use of sharps in the containment system is required.

## 5.8 Emergency/incident response

Because of the complexity of the engineering, design and construction of facilities using maximum containment measures, in either cabinet or suit configuration, a separate detailed work manual should be developed and tested in training exercises.

As with both core requirements and heightened control measures, an emergency programme must be devised; this will be more complex for a facility with maximum containment measures. National and local health authorities should actively cooperate in preparing this programme. Other emergency services, for example, fire, police and designated receiving hospitals, should also be involved.

## 5.9 Occupational health

In addition to the risk control measures outlined in the core requirements and heightened control measures, a system must be in place to provide 24-hour help in case of an emergency.

Working policies should ensure that the number of hours worked in the laboratory on a single occasion is kept to a minimum to prevent physical and/or mental fatigue. Injuries, in particular percutaneous injury such as from a needlestick or bites from infected animals, sustained in the laboratory carry an elevated risk due to the consequences of any subsequent infection because of the nature of the biological agents being handled. Such events must be reported immediately and appropriate first aid and/or prophylaxis precautions taken as applicable. Depending on the incident, personnel should monitor and record body temperature and any symptoms, for example, headache, fever and general malaise, for an agreed period of time. If body temperature increases or disease-specific symptoms are noted, arrangements should be made for medical advice and support and for transfer to a suitable health care facility for isolation and appropriate medical care.

# TRANSFER AND TRANSPORTATION

It is often necessary to transport specimens, biological materials or waste that are known or expected to contain biological agents between rooms, laboratories or facilities. In some cases, the material may need to be transported to laboratories in other cities, regions or even countries for further testing, treatment or storage. For the purpose of transport, materials from the laboratory that may contain biological agents are known as infectious substances; these include cultures, patient or animal specimens, infected body parts or organs, and biological products such as live attenuated vaccines or similar therapeutic products. Genetically modified organisms, if they are capable of causing infection in humans or animals, will also fall under this category.

Transportation of infectious substances may be subject to various national and/or international regulations, depending on the origin, destination and/or the mode of transport being used. Independent operators involved in the process (such as couriers, airlines or logistics services) may also request additional protocols. Irrespective of the regulations that apply, the aim is always to reduce the likelihood of an exposure to and/or a release of the infectious substance in order to protect personnel, the community and/or the surrounding environment.

Transferring or transporting infectious substances within or between laboratories should always be undertaken in a way that minimizes the potential for drop, spillage, collision or similar events. The following subsections provide an overview of the main issues to consider in the transfer or transport of infectious substance.

## 6.1 Transfer within the laboratory

Moving infectious substances within the laboratory, for example, from a BSC to an incubator, should be undertaken following GMPP to prevent incidents of cross contamination and inadvertent spillage. Additional measures to consider include the following:

- Use sealed containers, such as screw-capped tubes. Snap-cap lids should be avoided as they are less secure.
- Use deep-sided and leak-proof trays or boxes made of smooth impervious material (for example, plastic or metal), which can be effectively cleaned and disinfected. Locking plastic containers and storage containers are an option.

- If using racks, vials or tubes, trolleys can be used for more stable transport, as they are less likely to result in multiple spillages if a worker trips or falls.
- If using trolleys, ensure they are loaded so that substances cannot fall off, for example, by securing the load or using some form of guard rail or raised sides.
- Make sure spill kits are readily available for use in the event of a spillage during transfer, and available personnel are trained in their use.

## 6.2 Transfer within a building

In addition to the considerations above, the transfer of infectious substances between rooms, departments or laboratories in the same building must be planned, organized and carried out in a way that minimizes transit through communal areas and public thoroughfares.

Transfer containers must be suitably labelled to identify their contents, and surfaces decontaminated before leaving the laboratory. Biohazard symbols (31) should be used on containers as a heightened control measure, if the biological agent being handled is associated with a higher likelihood of infection.

### 6.2.1 Pneumatic air tube systems

A pneumatic air tube transport system is a network of tubes that allows the movement of cylindrical containers around a building or campus using compressed air. It can provide a safe, efficient and rapid means to transport specimens containing infectious substances around a site. Personnel using the system at dispatch and reception points must be suitably trained on its use and informed of any associated risks. Dispatch personnel must be able to identify that the specimen is suitable for transport by this method, including the appropriate size/weight/shape to travel in the system, and that it is appropriately packaged/contained to prevent any exposure to or release of the infectious substance during the process.

## 6.3 Transfer between buildings on the same site

Issues that need to be considered for containers and layers of outer packaging to minimize the risks of leakage while transferring infectious substances between buildings are outlined below.

- Sealable plastic bags, plastic screw-top tubes and locking plastic containers can all be used in the transfer of infectious substances between buildings.

- In Figure 6.1 are examples of items that can be used for containment during transport.
- Redundant layers of packaging, as described in subsection 6.4.3, should be considered.
- Absorbent materials should be used between layers of packaging to absorb all infectious substances, if there were leakage.
- The outermost transport container should be rigid. It can vary widely depending on the resources available. A plastic box or small plastic ice chest (Figure 6.1.) is one option for the transport of infectious substances between buildings on the same site, as they are secure and easily decontaminated.

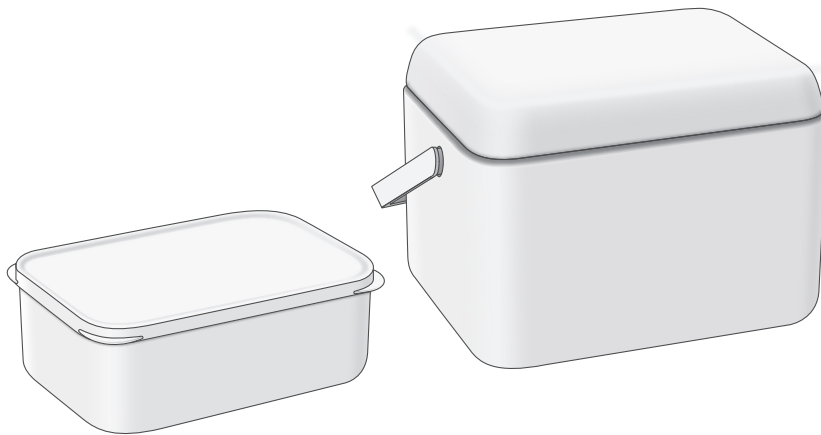

**Figure 6.1** Containers for transfer of substances between buildings on the same site

- Packaging should be labelled in a way that the sender, recipient and contents of the package are clearly identifiable. It should include biohazard symbols where appropriate.
- Personnel involved in the transfer must be provided with suitable awareness training on the risks present during the transfer process and how to safely reduce them.
- Spill kits must be readily available and appropriate personnel trained in their use.
- Recipients must be notified in advance of the transfer occurring.

## 6.4 Off-site transport of infectious substances

In some cases, infectious substances must be transported off-site for further processing, storage or disposal. This includes transport between sites of the same organization and from one organization to another. People at risk during off-site transportation are not only those involved in the transport, but also the public whose path might be crossed in transit. For this reason, ensuring infectious substances are safely contained and handled may be of interest to local, national and/or international authorities. Different national and international transport regulations have been developed to regulate packaging, labelling, marking and documentation of infectious substances to minimize the likelihood of exposure and/or release during transit. Most national regulations are adapted from the *United Nations Model Recommendations on the Transport of Dangerous Goods (32)* and overseen by independent compliance organizations or national authorities.

For transport purposes, these regulations classify materials that (may) contain biological agents as dangerous goods, under the class of “toxic and infectious substances”. Infectious substances are then further classified, based on a pathogen risk assessment, into subgroups for which different procedures are stipulated.

Other regulations may also apply to the shipment depending on the mode of transportation being used, if other dangerous goods are also present, and whether any national regulations are stipulated by the country of origin and/or the country receiving the shipment, including import or export licences as applicable.

The following subsections provide a short introduction to the regulations, classifications and safety controls that may be applied to the off-site transport of infectious substances. For more detailed information, please refer to documents listed in the reference section.

### 6.4.1 Regulation of the transport of infectious substances

Most of the regulations for the transport of infectious substances are based upon the United Nations (UN) model regulations (32). These regulations, reviewed every two years, should be consulted regularly to ensure that a laboratory's protocols for packaging, labelling, marking and transporting infectious substances comply with the current regulations. However, as these regulations are not intended to supersede any local or national requirements, and it is possible some national variations exist, national regulations for transport should always be consulted first.



Other international regulations for the transport of infectious substances include modal transport agreements, with variations for air (33,34), sea (35) and land (36,37) transportation. If national requirements do not exist, these modal agreements should be followed. Where multiple regulations exist, the more stringent ones must be applied. Other regulations or requirements may also apply to infectious substances if they are transported with other dangerous goods, including cooling materials such as dry ice or liquid nitrogen. Import and export requirements should also be considered, as should the application of other international agreements, for example, material transfer agreements where applicable (38).

Ultimately, it is the responsibility of the personnel sending the infectious substance (often referred to as the “shipper”) to ensure that they are familiar with all applicable regulations and/or variations that apply to their shipment and that they comply with them. Shippers must consult the relevant authorities to determine whether they are able to comply with these requirements before starting the shipment process.

All personnel who participate in any part of the transport of a dangerous good, including infectious substances, must have training on the applicable regulations to a proficiency level appropriate for their job responsibilities.

This may include general familiarization and awareness training, functional training on packaging, labelling and documentation, and safety training including best practice for handling dangerous goods to avoid incidents as well as emergency/incident response information. For certain types of infectious substances, a formal certification may be legally required, proving competence in these areas.

### 6.4.2 Classification of infectious substances

For transport purposes, infectious substances (cultures, human or animal specimens, biological products such as live-attenuated vaccines, infectious genetically modified organisms or medical/clinical wastes) may be further subdivided into the following classifications based on the pathogenicity of the biological agent it contains (or is suspected to contain): Category A, Category B and Exempt human/animal specimens. Each classification is assigned identifiers which includes a proper shipping name, and/or a unique four-digit UN number (32), which can be used to clearly identify the substance composition and hazardous nature of the biological agent, and indicate the specific transport requirements to be applied.

A brief introduction to infectious substances classifications and summary of the physical and procedural risk control measures that may apply are given below. Figure 6.2 also shows a flowchart which summarizes the various classifications and their features. More specific information on transport requirements can be found in the WHO guidance on the shipment of infectious substances (39) or should be sought from applicable regulations and agreements, depending on the transport conditions.

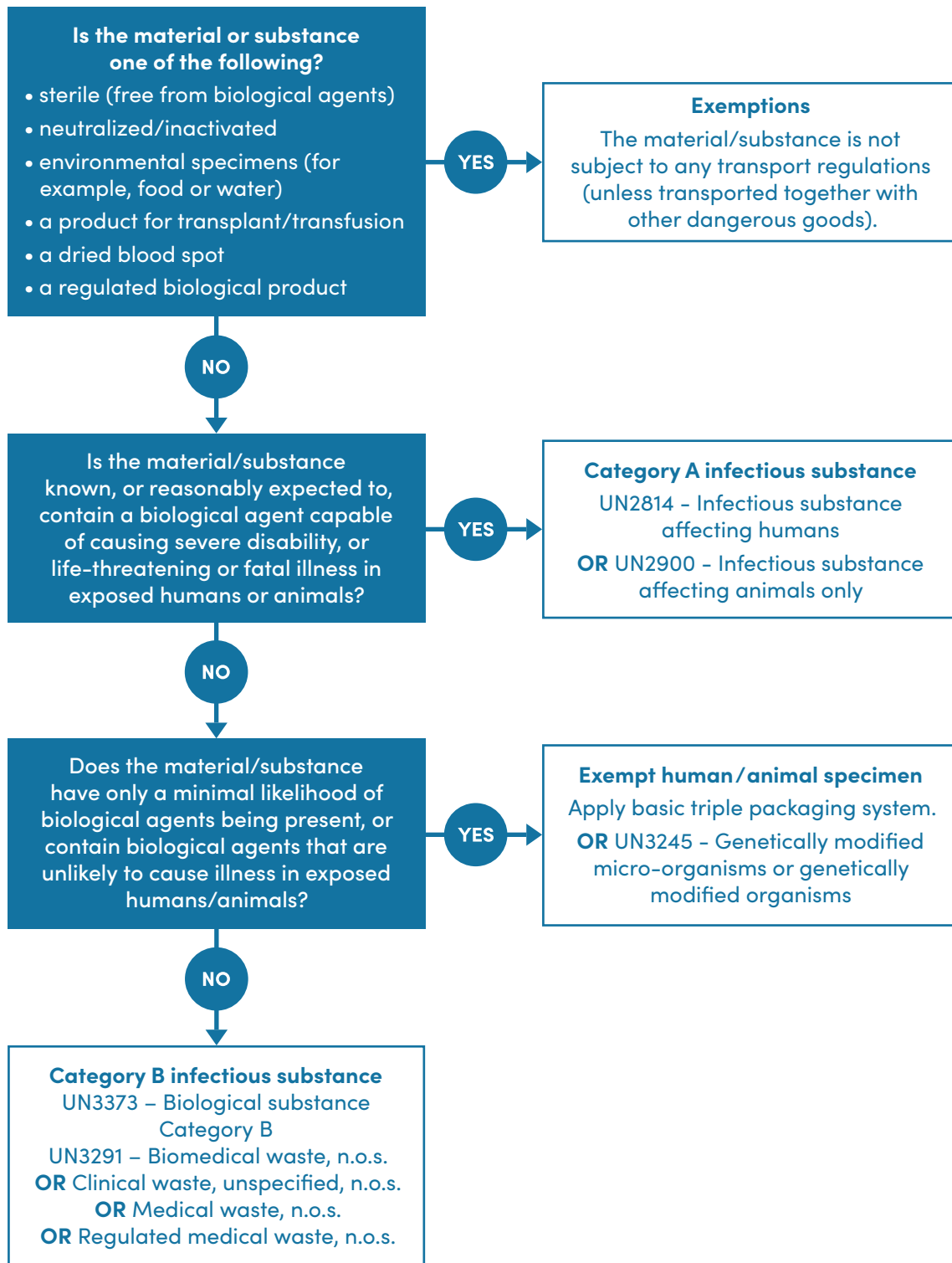

**Figure 6.2** Classification of infectious substances for transportation

### Category A and B infectious substances

Categories A and B infectious substances are the two most important classifications used when transporting biological agents (or material containing biological agents) off the laboratory site. The main difference between the two classifications relates to the consequences (severity of outcomes) of an infection with the biological agent being transported if an incident were to occur while in transit.

Category A infectious substances are defined as any material(s) known or reasonably expected to contain, biological agents capable of causing permanent disability, or life-threatening or fatal disease in otherwise healthy humans or animals. For the purposes of transport, these substances carry the highest biosafety and biosecurity risks and are therefore subject to the largest number of risk control measures, including regulated packaging of materials in a triple layer configuration, strict labelling criteria and detailed documentation processes. All people involved in the shipment of Category A infectious substances must be formally certified by an appropriate authority as determined by the relevant regulations.

An indicative list of the biological agents included in Category A can be found in the relevant regulations on transport of infectious substances (32-37), and in the WHO guidance document on this subject (39).

However, the indicative list of biological agents is not exhaustive and does not include new or emerging pathogens whose properties are unknown. In this case, classification must be based on available clinical evidence, local endemic conditions, the source of the infectious substance and sound medical judgement. If there is any doubt as to whether a substance meets the criteria, it must be considered Category A for transport purposes.

Category B infectious substances are defined as any material(s) containing biological agents capable of causing infection in humans or animals, but which do not meet the criteria for inclusion in Category A. These substances are also subject to strict regulation, including a triple-layer of packaging materials, special labelling and documentation. However, these are generally less stringent than for Category A infectious substances, depending on the applicable national regulations.

A summary of the main requirements for the classification, identification, packaging, labelling and documentation when transporting Category A and Category B infectious substances is provided in Table 6.1.

**Table 6.1** Summary categorization, documentation, packaging and labelling of infectious substances for transport

	CATEGORY A	CATEGORY B
<b>Definition</b>	Containing a biological agent known, or reasonably expected, to cause permanent disability, or life-threatening or fatal disease	Containing a biological agent capable of causing infection in susceptible humans or animals, but which does not meet the criteria for inclusion in Category A
<b>Identifiers (UN number and proper shipping name)</b>	<ul style="list-style-type: none"> <li>▪ UN2814: Category A infectious substances (affecting humans or zoonotic infectious substances)</li> <li>▪ UN2900: Category A Infectious substances (affecting only animals)</li> <li>▪ UN3549: Category A solid medical waste</li> </ul>	<ul style="list-style-type: none"> <li>▪ UN3291: Category B clinical or medical waste</li> <li>▪ UN3373: Category B infectious substances (for all other substances or materials including human or animal material, cultures and biological products)</li> </ul>
<b>Documentation</b>	<ul style="list-style-type: none"> <li>▪ An itemized list of contents (placed between the secondary and outer packaging)</li> <li>▪ Names and addresses of the shipper and the receiver</li> <li>▪ A dangerous goods transport document (dangerous goods declaration)</li> <li>▪ Additional documentation may be required depending on the modal requirements (for example, air waybill for air shipments) or national regulations (for example, import/export permits)</li> </ul>	<ul style="list-style-type: none"> <li>▪ An itemized list of contents (placed between the secondary and outer packaging)</li> <li>▪ Names and addresses of the shipper and the receiver</li> <li>▪ Additional documentation may be required depending on the modal requirements (for example, air waybill for air shipments) and/or other national requirements (for example, import/export permits)</li> </ul>
<b>Packaging</b>	<ul style="list-style-type: none"> <li>▪ Triple packaging required to comply with UN packing instruction P620</li> <li>▪ Packaging must show a UN specification mark, indicating compliance with testing requirements for Category A infectious substances packaging</li> </ul>	<ul style="list-style-type: none"> <li>▪ UN3291: single packaging acceptable provided that: enough absorbent material is present to absorb the entire amount of liquid, the package is leak-proof, and/or any sharp items are contained within puncture-resistant packaging</li> <li>▪ UN3373: Triple packaging required (for air transport, either the secondary or outer package must be rigid) which complies with and is packaged according to UN packing instruction P650</li> </ul>

UN = United Nations.

### Exempt human (or animal) specimens

Substances or materials derived from human or animal patients (that are clinical specimens) for which there is a minimal likelihood that infectious biological agents are present, are defined as exempt human or exempt animal specimens. This means they are exempt from many of the stringent criteria applied to Category A and Category B infectious substances, especially for marking, labelling and documentation. However, exempt specimens are still required to be packaged using redundant layers of packaging in a triple-layered system containing primary, secondary and outer packaging of adequate strength for the substance being transported.

Triple packaging for exempt specimens must be capable of preventing leakage of any and all liquid material held inside, and should be clearly marked on the outside with either Exempt Human Specimen or Exempt Animal Specimen as appropriate. If exempt specimens are being transported with other substances that meet the criteria for inclusion in another dangerous goods class, such as dry ice or other infectious substances, the relevant regulations for those substances must be followed.

### Exclusions

Some biological materials being transported off the laboratory site are known to be free of, or are extremely unlikely to contain, any biological agents. Such materials are excluded from any regulation on packaging, marking, labelling or documentation. These exclusions include:

- materials known to be free of infectious substances,
- biological agents within the material that have been inactivated or destroyed,
- biological agents within the material that are not pathogenic to humans or animals,
- dried blood spot or faecal occult blood specimens transported for analysis,
- environmental specimens not considered to be a significant hazard to health, and
- items for transplant or transfusion.

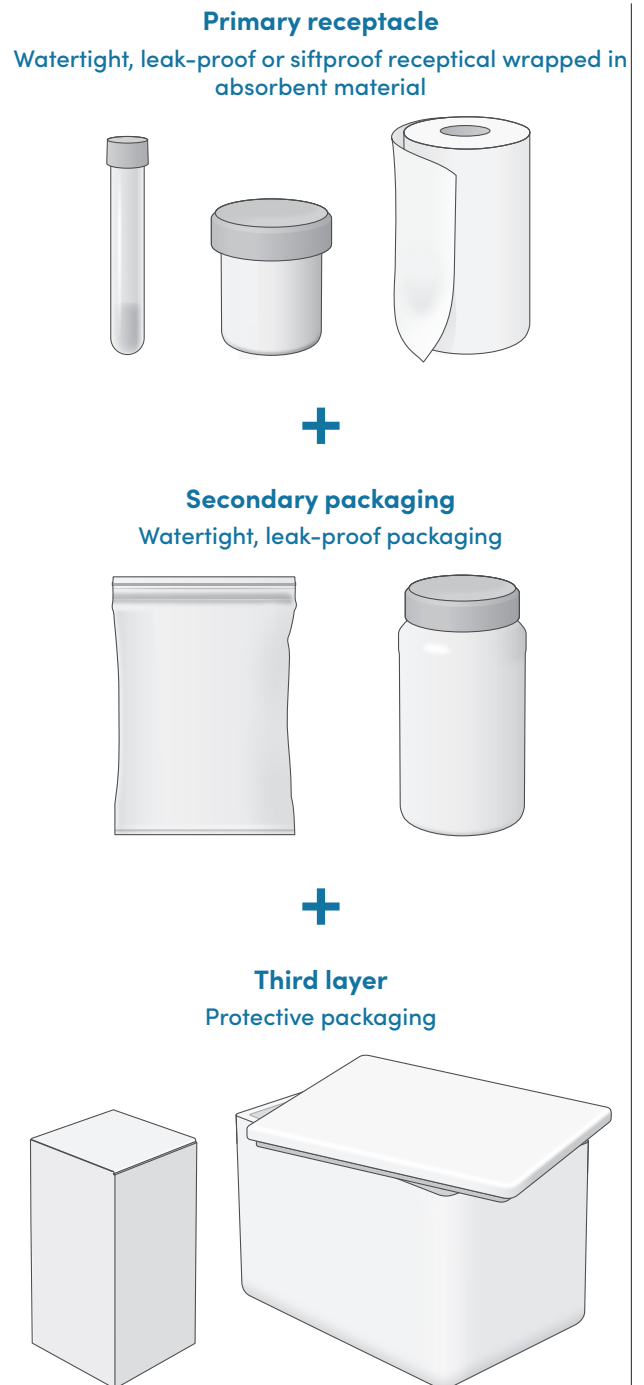
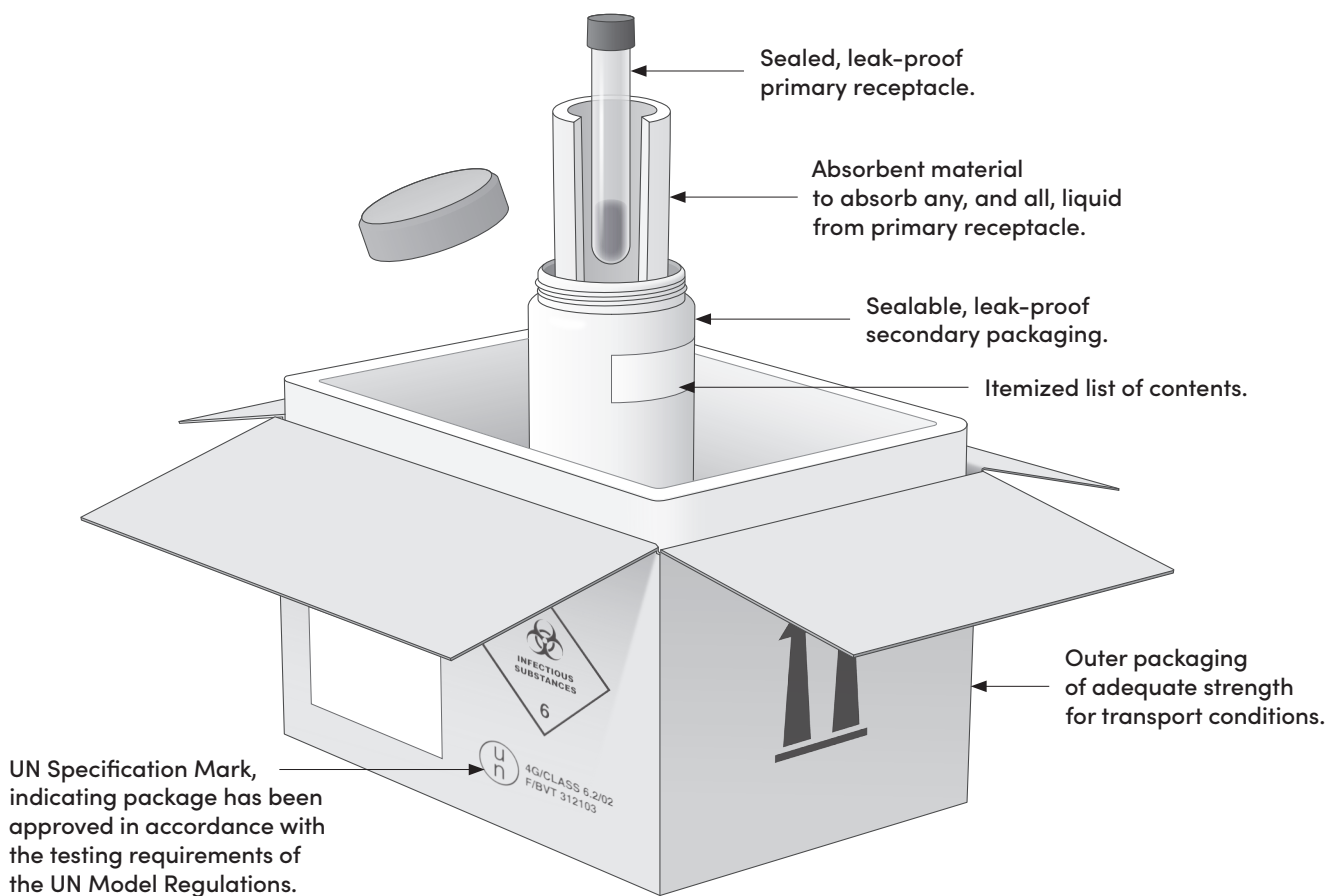

**Figure 6.3** Example of triple packaging for infectious substances

### 6.4.3 Triple packaging of infectious substances

Using redundant layers of packaging is a common method for controlling any leakage or breach of containment of an infectious substance to reduce the likelihood of exposure and/or release during transport. A triple packaging system is commonly recommended, and required by regulation, for all three classifications of infectious substances described in the previous sections.

A **triple package** consists of three layers (see example in Figure 6.3). The **primary receptacle**, containing the infectious substance must be watertight, leak-proof and appropriately labelled as to its contents. The primary receptacle must be wrapped in enough absorbent material to absorb its contents in the event spillage occurs. If multiple primary receptacles are packed together, cushioning material must be used to prevent contact between them.



**Figure 6.4** Example of triple packaging materials suitable for Category A infectious substances

**Secondary watertight, leak-proof packaging** is used to enclose and protect the primary receptacle(s). Several wrapped primary receptacles may be placed in a single secondary packaging. Some regulations may have volume and/or weight limits for packaged infectious substances.

**The third layer** protects the secondary packaging from physical damage while in transit. It is between the second and third outer layers that coolants, such as dry ice or liquid nitrogen, can be used if necessary. Such coolants are also classified as dangerous goods and may therefore be subject to additional requirements themselves, as outlined in applicable regulations. For example, when dry ice is used, the third layer must be capable of releasing carbon dioxide gas to prevent explosion. Specimen data forms, letters and other types of information that identify or describe the infectious substance and identify the shipper and receiver, and any other documentation required, must also be provided according to current applicable regulations.

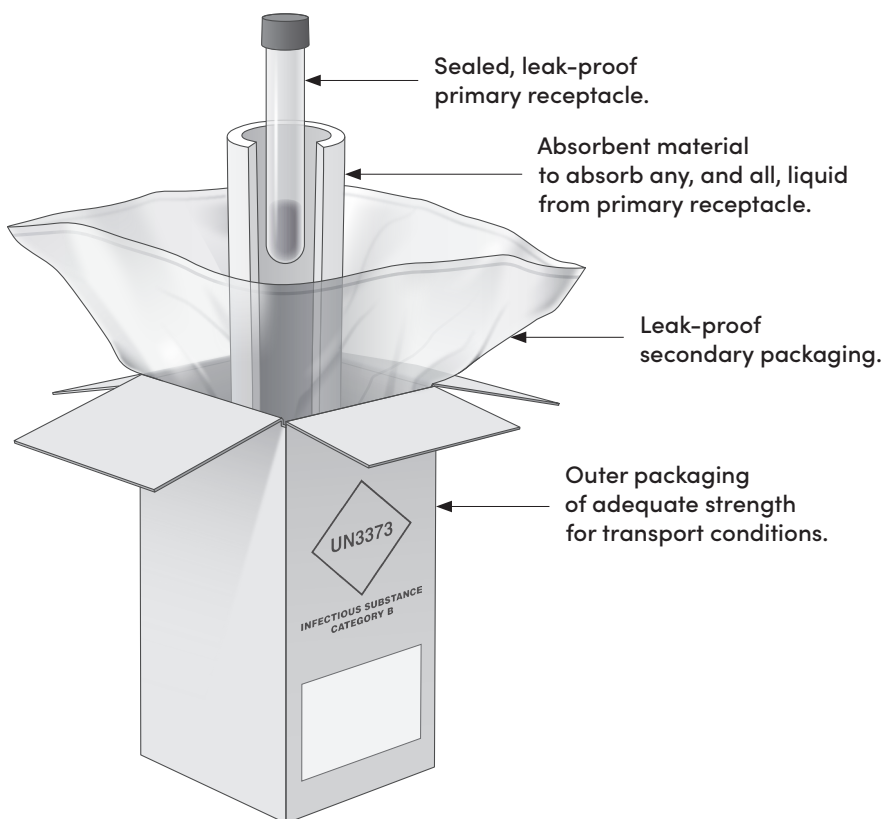

**Figure 6.5** Example of triple packaging materials suitable for Category B infectious substances

**The outer layer** of the triple package must also be marked and labelled appropriately, to provide the correct information about the hazards of the packaged contents for both for the infectious substance and any other dangerous goods that may be present, such as dry ice. General shipping information, such as the shipper and receiver of the infectious substance, and handling information, such as orientation arrows on the box, may also be required. As the exact requirements for the composition of the triple packaging may differ depending on the classification of the substance and mode of transport being used, applicable regulations must always be consulted to ensure the correct materials are used.

More detailed information on the specific transport requirements for categories A and B infectious substances is provided in the UN model regulations (32) as guidance's known as "packing instructions". These prescribe the components of packaging that must be used for various dangerous goods classes, as well as the standards that the material must meet to be approved for use. There are two different packing instructions that relate to infectious substances. P620 applies to all Category A shipments (both UN2814 and UN2900). It provides additional requirements to the basic triple packaging system. These include criteria to comply with rigorous package testing that demonstrate the ability to withstand internal pressures without leakage, and to withstand dropping, stacking and even conditioning (such as with water and temperature extremes). P620 also describes additional packaging requirements for shipments that include dry ice. An example of packaging material for Category A infectious substances is shown in Figure 6.4.

A more basic triple packaging system P650 applies for the transport of other classifications of infectious substances – Category B (Figure 6.5) or exempt human and animal specimens. Packaging compliant with P650 must also undergo drop-testing and internal pressure testing in some situations, although this is less stringent than that required for Category A infectious substance packaging.



# BIOSAFETY PROGRAMME MANAGEMENT

The effective management of biological risks is supported by established measures at both the national and institutional levels. Just as national governments and authorities must assess biological risks and apply nation-wide regulatory frameworks to control them, organizations in which biological agents are handled have an obligation to assess the biological risks that exist in their facility and apply appropriate risk control measures to protect their personnel, community and the environment.

A structured oversight system for managing biological risks implemented at the national level (for example, a regulatory framework) will inform and direct the mechanisms by which organizations can meet their related obligations. Organization-specific risk assessments can further guide the selection and implementation of appropriate risk control measures and mitigation strategies that reduce risks to acceptable. The management of this process requires an organization to develop a biosafety programme: a set of tools, information and associated actions that are overseen, and continuously improved upon, by an organization's senior management.

Effective management of a structured biosafety programme ensures the following activities have been undertaken.

- There is a commitment from senior management to appropriately address and manage the risks associated with the biological agents being handled.
- All risks associated with work activities have been identified, understood and controlled to an acceptable and practical level.
- Practice and procedure necessary to control risks have been put in place and are monitored regularly to ensure continued effectiveness and relevance.
- A framework has been developed for the appropriate training of personnel in biosafety practices and biosecurity awareness.
- The roles and responsibilities of all personnel are clearly set out and understood.
- Activities related to laboratory biosafety, and its associated policies and procedures, are aligned with national and international guidelines and regulations.

A biosafety programme is often a component of an overarching safety programme at the organizational level (that is one that holistically assesses and addresses all types of health and safety risk within an organization).

However, the independence of the biosafety programme and its management from the organizational governance structure will depend on the size and complexity of the facility. For example, a standalone biosafety programme may be necessary where high risks exist, or where complex or broad types of activities with biological material are conducted.

This section provides an overview of the foundational elements of a biosafety programme and how these can be managed at an institutional level. While the size and complexity of an organization dictates the specifics of a biosafety programme, these foundational elements, when based on a strong biosafety culture, provide a solid framework for the most effective biosafety programme.

Additional information and guidance on how to successfully implement and manage a biosafety programme can be found in *Monograph: biosafety programme management (17)*.

## 7.1 Biosafety culture

Biosafety culture is the set of values, beliefs and patterns of behaviour instilled and facilitated in an open and trusting environment by individuals throughout the organization who work together to support or enhance best practice for laboratory biosafety. This culture is crucial for the success of a biosafety programme, and is built from mutual trust and the active engagement of all personnel across the organization, with a clear commitment from the organization's management. Establishing and maintaining a biosafety culture provides a foundation upon which a successful biosafety programme can be developed.

## 7.2 Biosafety policy

An institutional biosafety policy is a document that describes the scope, purpose and objectives of the biosafety programme. A biosafety policy in place is a demonstration of the prominence of and commitment to biosafety within the organization.

## 7.3 Assigned roles and responsibilities

Although the responsibility for establishing and managing a biosafety programme, including defining and assigning roles and responsibilities, rests with the senior management of an organization, all facility personnel who may come into contact with biological agents are responsible for actively participating in the biosafety programme. Succession planning should be in place for management, scientific, technical and administrative personnel to ensure that critical knowledge of the safe and secure operation of the facility does not lie with just one individual in the event of unavailability or departure.

The various roles and responsibilities that should be assigned to personnel in order to successfully manage a biosafety programme are outlined in the following subsections.

### 7.3.1 Senior management

Senior management is responsible for the creation of policies and guidelines, as well as for the ongoing support of the biosafety programme. They are responsible for ensuring funding to support the programme and for providing oversight of the implementation and ongoing review of the programme components.

### 7.3.2 Biosafety committee

A biosafety committee is an institutional committee created to act as an independent review group for biosafety issues; it reports to senior management. The membership of the biosafety committee should reflect the different occupational areas of the organization as well as its scientific expertise.

### 7.3.3 Biosafety officer

A biosafety officer should be appointed to provide advice and guidance to personnel and management on biological safety issues. The role and knowledge of the biosafety officer is key to developing, implementing, maintaining and continually improving a biosafety and biosecurity programme. Biosafety officers should have sufficient training and experience so that they are competent to perform the role, and they should be allocated enough time and resources to do the job effectively. However, depending on the size and nature of the laboratory, the biosafety officer could be a contractor or could perform the duties part time.

### 7.3.4 Laboratory personnel and support personnel

All personnel within the organization who have access to the laboratory space or to the biological agents in the facility are responsible for supporting and contributing to a biosafety programme. The laboratory director/manager is responsible for implementing and promoting biosafety to ensure the safety of all personnel, contractors and visitors to the facility, and to protect the public and the environment from hazards arising from the work being performed in the laboratory. Laboratory and support personnel are responsible for applying biosafety in their daily activities.

## 7.4 Biosafety manual

A biosafety manual is a mandatory collection of all the organization-specific documents that describe the foundational elements of their biosafety programme. These may include policies, information about supporting programmes and plans, and organization-specific SOPs.

## 7.5 Biosafety and biosecurity risk assessment

The main goal of a biosafety programme is to effectively manage biological and biosecurity risks. An essential activity to achieve this objective is conducting risk assessments. A biosafety/biosecurity risk assessment is a systematic process of gathering and evaluating information to identify hazards, determine the associated risks and develop appropriate risk control strategies that, when implemented, reduce risks to acceptable risks.

For more specific information on how to conduct a risk assessment, please refer to section 2 risk assessment. Templates and additional guidance can also be found in *Monograph: risk assessment (18)*, and *Monograph: biosafety programme management (17)*.

## 7.6 Supporting programmes and plans

The outcomes of biosafety and biosecurity risk assessments will inform the selection of risk control measures that are needed to address identified risks. The correct implementation of these measures must then be managed through the development and management of several supporting programmes or systems. The details of these need to be accessible to personnel through the biosafety manual, and which may include:

- biosecurity plan and laboratory access system,
- occupational health programme,

- personnel management and training programme,
- SOP development,
- facility design plans,
- laboratory equipment purchase, installation and maintenance plan,
- decontamination and waste management system,
- emergency/incident response,
- record and document management system,
- inventory control plan, and
- communication plan.

The development and approval of these supporting programmes and plans are directed by senior management, with the support of relevant expertise (for example, biosafety officer, biosafety committee, engineers, facility-specific management).

Descriptions and key considerations for the biosafety manual and each of the supporting programmes and plans can be found in *Monograph: biosafety programme management (17)*. Key risk control strategies that need to be included in these plans can be found in section 3 core requirements, section 4 heightened control measures and section 5 maximum containment measures.

## 7.7 Reports and reviews

Biosafety programmes are dynamic and require regular assessment and flexible strategies to ensure ongoing and sustained improvement. The biosafety programme must be reviewed periodically to ensure continued suitability, adequacy and effectiveness. To do this, it is essential that organizations have record-keeping and review systems which must include the features outlined in the following subsections.

### 7.7.1 Incident reporting and investigation

Assessments of the type and severity of incidents, including those that do not result in exposure or release (that are near misses), that may occur in the laboratory provide key information to guide the nature and scope of responses and future preparedness.

Performing a thorough review of all incident reports is an important part of biosafety programme management because it provides information on what worked and what did not. It also provides an opportunity to perform a root cause analysis to identify any underlying factor(s) that might have increased the likelihood of the incident (or near miss) occurring. Results from incident investigations should be used to update and improve emergency response, and are a training opportunity on lessons learned to prevent future occurrences.

### 7.7.2 Audits and inspections (internal and external)

Many laboratories implement a cooperative inspection programme where laboratory personnel are directly responsible for periodic self-audits (self-assessments) coupled with a less frequent, but more in-depth, evaluation with the biosafety officer and/or members of the biosafety committee. In some cases, laboratories may also have external audits and/or inspections, for example, as part of a certification process, under the national regulatory framework, or in an international mentoring programme. These assessments can provide information on the effectiveness of a biosafety programme, and the results can be analysed to identify weaknesses that may need to be addressed.

### 7.7.3 Other reports

In addition to incident reports and laboratory assessments, a biosafety programme may also record and review other information such the outcomes of training exercises and drills and employee surveys in order to identify additional biosafety improvement opportunities.

Further guidance on and templates useful for the improvement and review of the biosafety programme can be found in *Monograph: biosafety programme management (17)*.

# LABORATORY BIOSECURITY

Laboratory biosecurity refers to institutional and personnel security measures designed to prevent the loss, theft, misuse, diversion or intentional release of biological agents being handled in the laboratory. Addressing laboratory biosecurity risks in many ways parallels and complements that of biosafety risk management. Effective biosafety practices are the foundation of laboratory biosecurity and biosecurity risk control measures must be performed as an integral part of an institution's biosafety programme management.

There are many challenges and caveats associated with implementing biosecurity policies and procedures. For example, many biological agents against which protection is needed can be found in their natural environment. In addition, biological agents of interest might only be used in very small quantities, or may be capable of self-replicating, making them difficult to detect or reliably quantify. In some cases, the process of quantification may itself pose biosafety and biosecurity risks. Furthermore, while there is potential for malicious use of these biological agents, their use is valuable for many legitimate and benign diagnostic, commercial, medical, and research applications. For this reason, it is essential to properly assess potential biosecurity risks and establish appropriate risk control measures that can reduce risks without hindering scientific processes and progress. These measures should comply with national standards and regulatory procedures and be proportionate to the assessed risks.

To achieve this, an approach similar to the biosafety risk assessment framework should be undertaken, with specific focus on biosecurity, to identify whether an institution possesses biological agents that may be attractive to those who may wish to use them maliciously. The depth of this biosecurity risk assessment should be proportionate to the identified risks. For most laboratories, biosecurity risk assessment can often be combined with a biosafety risk assessment rather than being a stand-alone activity.

As with biosafety, the biosecurity risk assessment process also includes the development of a strategy to manage the biosecurity risk by selecting and implementing biosecurity risk control measures. A laboratory biosecurity programme is required to prepare, implement, oversee and review these processes, according to the requirements of the facility. In many cases, this can be combined with biosafety programme management, although it may need to be a stand-alone programme when the biosecurity risks identified are severe and/or numerous.

The following subsection briefly describes some of the key elements of a laboratory biosecurity programme, including its risk assessment framework. Detailed information on performing risk assessments can be found in *Monograph: risk assessment (18)*. For details on laboratory biosecurity, please refer to the WHO publication: *Biorisk management. Laboratory biosecurity guidance (40)*.

## 8.1 Biosecurity risk assessment

Biosecurity risk assessments follow the same framework outlined earlier for biosafety.

### 8.1.1 Gather information

Collect information on: the type of biological agents available, their physical location, the personnel required to access the laboratory premises either to handle the agents or for other reasons such as service and maintenance, and those responsible for the biological agents.

### 8.1.2 Evaluate the risks

Assess how the information gathered relates to the likelihood of someone gaining access to the identified biological agents and the consequences of a deliberate release of those agents. Compare the two factors to establish what the overall/initial risks are.

### 8.1.3 Develop a risk control strategy

Determine the minimum security standards required for work to be allowed to proceed with the identified biological agents (that is the acceptable risk).

### 8.1.4 Select and implement risk control measures

Biosecurity risk control measures can include both procedural and physical security systems. The risk assessment should include a clear definition of the threats the risk control measures are designed to protect against and clarify the performance requirements of any physical security systems. Biosecurity risk control measures are described in more detail later in this section.

Assessment of the suitability of personnel, security-specific training and rigorous adherence to pathogen protection procedures are ways to enhance laboratory biosecurity.



### 8.1.5 Review risks and risk control measures

Successful operation of the biosecurity programme should be verified through periodic exercises and drills. Likewise, an institutional laboratory biosecurity protocol should be established to identify, report, investigate and remedy breaches in laboratory biosecurity. The involvement and roles and responsibilities of public health and security authorities in the event of a security breach must be clearly defined.

All such efforts must be established and maintained through regular vulnerability, threat and biosecurity risk assessments, and regular review and updating of procedures. Checks for compliance with these procedures, with clear instructions on roles, responsibilities and remedial actions, should be integrated into a laboratory biosecurity programme.

## 8.2 Inventory control

A comprehensive programme of accountability is necessary to establish adequate control of at-risk biological agents, and to discourage theft and/or misuse. Procedures that can be used to achieve this include compilation of a detailed inventory, including description of the biological agent(s), its quantities, storage location and use, the person responsible, documentation of internal and external transfers, and an inactivation and/or disposal of the materials. A periodic review is recommended and any discrepancies should be investigated and resolved.

*The biological agent inventory should be up-to-date, complete, accurate and updated regularly to ensure that there is appropriate control and accountability.*

## 8.3 Information control

Processes and procedures must also be used to protect the confidentiality and integrity of sensitive information held in the laboratory that could be used with malicious intent. Within the scope of the biosecurity programme, it is important to identify, label and protect sensitive information against unauthorized access. Sensitive information includes research data, diagnostic results, information on animal experiments, lists of key personnel (for example, IT and biosafety contacts), security plans, access codes, passwords, storage locations and biological agent inventories. Sharing sensitive information with unauthorized individuals must be strictly prohibited.

*Confidential: Information that is protected or restricted from unauthorized or accidental access and/or dissemination.*

## 8.4 Personnel control

The effectiveness of any procedural controls for biosecurity are ultimately determined by the training, capability, reliability and integrity of the personnel. Proper personnel management is essential for the functioning of a laboratory. It ensures that daily work practices and procedures are being performed by suitable personnel who behave in a reliable and trustworthy manner. In addition to laboratory personnel, laboratory access request and approval processes for visitors and other outside personnel must be established to ensure that there is a legitimate need for access, and that appropriate vetting and escorting procedures are followed.

Laboratory biosecurity training should be provided in addition to biosafety training for all personnel according to the outcomes of the risk assessment. Such training should help personnel understand the need to protect biological agents and the rationale for the specific biosecurity measures that have been put in place. It should also include a review of relevant national standards and the institution-specific procedures. Security-related roles and responsibilities of personnel in everyday and emergency scenarios should also be defined. Not all positions present the same level of biosecurity risk and training and requirements should be commensurate with those risks. Succession planning should be in place for management, scientific, technical and administrative personnel to ensure that critical knowledge of the safe and secure operation of the facility does not lie with just one individual in the event of unavailability or departure. Documented procedures for terminated or departing personnel must be established (for example, transfer of accountability for inventories and equipment, retrieval of property belonging to the laboratory, cancellation of access). Procedures that should be incorporated when implementing personnel management programmes include: establishing specifications for assessing suitability before employment, developing procedures to ensure only approved individuals are able to access at-risk biological agents and regulating the sharing of keys, combinations, codes, key-cards or passwords.

## 8.5 Physical security control

Physical security countermeasures are used to prevent unauthorized access of outside adversaries (that is those who do not have a legitimate presence in the facility and have malicious intent such as criminals, terrorists and extremists/activists) and also to minimize the threat from insiders (that is those who have a legitimate presence in the facility such as employees and approved visitors) who do not require access to a particular asset. Physical security systems promote not only biosecurity objectives, but also directly support biosafety by limiting access to the laboratory and other potentially hazardous areas.

An effective physical security system incorporates a variety of elements to enhance a facility's capability to deter, detect, assess, delay, respond to, and recover from a security incident.

These elements include boundaries, access controls, intrusion detection, alarm assessment and response, and they are typically graded. A graded protection system increases security incrementally and forms risk-based layers of protection around the facility's assets. The highest level of protection should be given to those assets whose loss, theft, compromise, and/or unauthorized use will have the most damaging effect on national and potentially international security, and/or the health and safety of employees, the public, and the environment. In addition, these elements should be selected and implemented after a site-specific biosecurity risk assessment to ensure that they are all practical, sustainable and commensurate with identified risks.

## 8.6 Transport control

The transfer of biological agents must comply with national and international rules for packaging, marking, labelling and documentation as outlined in section 6 transfer and transportation. This process should be controlled to a level proportionate with the assessed biosecurity risks of the biological agent being transported to ensure proper oversight within the biosecurity programme.

Procedures may include ensuring that biological agents are ordered from legitimate providers and that they reach their intended destination using approved couriers. Procedures for shipper, carrier and receiver responsibilities to ensure that biosecurity risks are controlled should be written and followed as appropriate. Vulnerabilities exist from the moment items are removed from secure areas as an increased number of people may now have access to them.

Transfers should be prearranged and preapproved by responsible parties and can use chain of custody documentation (or equivalent) for proper record keeping if necessary based on the outcomes of a biosecurity risk assessment. Inventories must be updated to reflect incoming and outgoing specimens, including internal and external transfers.

## 8.7 Emergency/incident response

Even the most well prepared laboratory may experience unintentional or intentional incidents or emergencies despite existing prevention or risk control measures. Effective incident response is a risk control strategy that can reduce the consequences of these unknown events through planning and preparation for potential incidents (such as discrepancies found in inventories, missing biological agents or unauthorized persons in the laboratory), and may help detect, communicate, assess, respond to and recover from actual events. An incident response protocol should be written and followed to ensure proper reporting, and to facilitate investigation, root-cause analysis, corrective action and process improvement.

Drills and exercises can also be used in the planning and preparation stages to test the responses to simulated incidents or emergencies. They can help identify gaps and other improvement opportunities. Plans should be reviewed and updated at least annually, and the information obtained through drills, incident reports and investigations should be used to make necessary adjustments and improvements.

## 8.8 Emerging biological risks

Emerging biological risks includes genetically modified microorganisms, synthetic biology, gain-of-function research, stem cell research, gene editing and gene drives. Advances in life sciences research are inextricably linked to improvements in human, plant and animal health. Promotion of high-quality life sciences research that is conducted responsibly, safely and securely can improve global health security and contribute to economic development, evidence-informed policy-making, and public trust and confidence in science. However, countries, laboratories and scientists must also consider the risks posed by incidents and/or the potential deliberate misuse of life sciences research and select appropriate risk control measures to minimize those risks in order to conduct necessary and beneficial life sciences research.

When considering the ethical issues related to life sciences in a risk assessment, no single solution or system will suit all countries, institutions or laboratories. Each country or institution that assesses the extent to which it has systems and practices in place to handle the risks posed by incidents or the potential deliberate misuse of life sciences research will need to decide which measures are most appropriate and relevant according to their own national circumstances and contexts.

*Do not focus on any one particular issue or technology (genetically modified microorganisms, dual use research of concern, synthetic biology, gain-of-function research, stem cells, gene editing, and gene drives) but rather use one framework for which risks can be assessed and managed regardless of the technology involved.*

When conducting research with emerging technologies, for which limited information currently exists, the scientific community must:

- Promote a culture of integrity and excellence, distinguished by openness, honesty, accountability and responsibility; such a culture is the best protection against the possibility of accidents and deliberate misuse, and the best guarantee of scientific progress and development;

- Provide direction for biosafety/biosecurity oversight and the risk assessment process for emerging technologies in the life sciences, and as additional information is obtained over time, contribute to better understanding of their risks and biosafety/biosecurity needs;
- Monitor and assess the scientific, ethical and social implications of certain biotechnologies and, as warranted, monitor the development of those technologies and their integration into scientific and clinical practice.

## 8.9 Dual use research of concern

Dual use research of concern is life sciences research that, based on current understanding, has the potential to provide knowledge, information, products or technologies that could be directly misapplied to create a significant threat with potential consequences to public health and safety, agricultural species and other plants, animals, and the environment.

Awareness of the dual use of agents, equipment and technology should also be considered in the development of laboratory biosecurity programmes where applicable. Laboratories should take responsibility for the dual-use nature of such agents and experiments, such as genetic modification, and follow national guidelines in order to decide on the adoption of appropriate biosecurity measures to protect them from unauthorized access, loss, theft, misuse, diversion or intentional release. The potential misuse of biosciences is a global threat that requires a balanced approach to laboratory biosecurity so that legitimate access to important research and clinical materials is preserved.



# NATIONAL / INTERNATIONAL BIOSAFETY OVERSIGHT

Biosafety and biosecurity are central to the global protection of human health from hazardous biological agents. They are closely linked to animal health, environmental protection and safeguards against the misuse of biological agents. Biosafety, a term used to describe the collection of practices, technologies and containment principles which prevent unintentional exposure to and/or the release of biological agents, is of growing importance as a result of globalization, technological progress and the rapid increase in communication, transport and trade. Risks related to outbreaks of emerging and highly infectious diseases in an international context emphasize the need for effective measures to prevent, detect and respond to outbreaks and other public health hazards as defined by the *International Health Regulations (13)*. More information about biosafety and biosecurity in outbreaks can be found in *Monograph: outbreak preparedness and resilience (23)*.

In this context, biomedical laboratories have a key role in ensuring that biological agents are identified, safely stored and controlled in adequately equipped facilities according to best practice. Often, these laboratories also have a central function in biological risk capacity-building, promotion of a culture of responsibility, and health protection for all stakeholders involved. It is for this reason that the effective control of biological risks most often begins at the national level.

Often, national authorities establish national policies, legislation, regulation and/or guidance documents which stipulate the type of risk control measures that must be implemented by a laboratory if they are to be authorized to operate. Where this is the case, an oversight system has generally been developed to ensure compliance with the regulations. It is important that such regulations strike a balance between ensuring national risk mitigation and allowing laboratories enough flexibility to operate sustainably, within their means, and continue their work to benefit the communities they serve. Rapid disease diagnostics, innovative treatments and new knowledge about biological agents are all essential activities to improve local and global health care and should always be prioritized.

Development of national regulations for biosafety begins with risk assessment – a systematic process of gathering and evaluating information to support the development of a regulatory framework that is risk- and evidence-based. The steps involved in performing a national risk assessment are similar to the steps described later in this manual for performing a laboratory risk assessment to select appropriate and proportionate risk control measures for the identified biological risks associated with the work being performed.

However, the way in which the identified risks are evaluated and prioritized at the national level may be different because a wide range of factors must be considered by governments. These may include the potential impact on public health, the country's size, location, resources, and even the risk that is acceptable to the general public.

*A national level risk assessment considers the likelihood that a biological agent will cause infection and/or an outbreak in human or animal populations and the social, economic and/or health consequences that such an infection could have.*

The implementation of and compliance with the relevant stakeholders may be monitored by oversight mechanisms delivered by nationally appointed authorities. Collectively, these tools and processes form a national regulatory framework for biosafety and, in most cases, also biosecurity. This framework may only be for biosafety and biosecurity, but often it is a part of a larger framework for general population health, One Health, and occupational health and safety and/or security, among others.

Across countries, the way in which regulatory frameworks are applied to laboratory operations varies greatly. While some countries are highly regulated and have detailed legislation on biosafety and biosecurity that includes established networks of stakeholders with well-defined responsibilities and processes, other countries lack regulatory guidance on laboratory biosafety and biosecurity. Given the challenges countries might face because of limited resources on the one hand and emerging diseases and the (mis)use of advanced technologies on the other, controlling biological risks at the national level may require context-specific consideration to devise the most appropriate approach for a country. Although outside the scope of this manual, numerous international initiatives, groups and guidance documents exist which aim to assist countries in developing the most appropriate and effective framework for controlling their biosafety and biosecurity risks (41,42).

In general terms, there are three common approaches that can be used by national authorities to assess risks and apply regulatory frameworks. Each approach uses a classification system to group either the biological agent or the work being performed with them into categories to which different regulations can be applied. Many countries use a combination of these approaches in order to appropriately address nationally identified risks and to cover the various activities where biological agents may be handled in different sectors that may extend beyond public health to other sectors. A summary of these three approaches is provided in Table 9.1.



**Table 9.1** Approaches for developing national biosafety regulations as part of a national legislative framework for biosafety

APPROACH	METHOD
Activity-based	The development of regulations that apply to the types of work being performed on a biological agent (rather than the biological agent itself). For example, regulations developed for all work involving recombinant DNA.
List-based	The development of one or more sets of national regulations and an accompanying list of all the biological agents for which those regulations apply.
Risk or hazard group	Biological agents are classified into “risk” or “hazard groups” based upon each agent’s characteristics and epidemiological profile. The higher the risk or hazard group, the higher the likelihood that the agent will cause and spread infection in humans or animals in the country, and/or the more severe the consequences of that infection will be to individual and public health, if it were to occur. Regulations are then developed that apply to each of the risk or hazard groups. Classical definitions for risk groups 1 to 4 can be seen in footnote 1.

Regardless of the approach used, the classification of biological agents and/or the work being performed with them should not be considered static, nor should it be universally applied across jurisdictions. Classification can vary according to contextual factors (for example, geography, time, process), so the application of one country’s classification system to another country should be avoided as it could create confusion and result in inadequate or excessive risk control measures.

Furthermore, if national regulatory frameworks are to remain flexible, to reflect changing knowledge of regulated pathogens and/or activities and advances in technologies, periodic review and updating of classification systems must be performed and reflected in updated oversight tools (for example, regulations, policies, standards, guidelines).

<sup>1</sup>Risk Group 1 (no or low individual and community risk): A microorganism that is unlikely to cause human or animal disease. Risk Group 2 (moderate individual risk, low community risk): A pathogen that can cause human or animal disease but is unlikely to be a serious hazard to laboratory personnel, the community, livestock or the environment. Laboratory exposures may cause serious infection, but effective treatment and preventive measures are available and the risk of spread of infection is limited. Risk Group 3 (high individual risk, low community risk): A pathogen that usually causes serious human or animal disease but does not ordinarily spread from one infected individual to another. Effective treatment and preventive measures are available. Risk Group 4 (high individual and community risk): A pathogen that usually causes serious human or animal disease and that can be readily transmitted from one individual to another, directly or indirectly. Effective treatment and preventive measures are not usually available. Source: WHO Laboratory Biosafety Manual, 3rd edition (2004).

While this manual primarily focuses on the technical and medical/scientific aspects of biosafety at the institutional level, it is important to begin by recognizing that national and international biosafety oversight may play an important role in influencing biosafety practices at the laboratory level. Laboratory management needs to be aware of any regulatory conditions that apply to their work and comply with them. It is equally important that authorities developing or reviewing national biosafety regulatory frameworks fully understand the implications of their framework on the work being performed at the laboratory level. For this reason, communication between stakeholders at the national and laboratory levels is key to ensure a good understanding of the importance and the risks of working with biological agents, to apply appropriate and proportionate risk control measures, to comply with national and/or international obligations (43,44), and to develop a safety culture built on a national commitment to biosafety (45).

## References

1. World Health Organization. Laboratory biosafety manual. First edition. Geneva: World Health Organization; 1983
2. World Health Organization. Laboratory biosafety manual. Second edition. Geneva: World Health Organization; 1993
3. World Health Organization. Laboratory biosafety manual. Third edition. Geneva: World Health Organization; 2004
4. Wurtz N, Papa A, Hukic M, Di Caro A, Leparac-Goffart I, Leroy E, et al. Survey of laboratory-acquired infections around the world in biosafety level 3 and 4 laboratories. *Eur J Clin Microbiol Infect Dis*. 2016 Aug;35(8):1247-58. doi: 10.1007/s10096-016-2657-1
5. Choucraallah D, Sarmiento L, Ettles S, Tanguay F, Heisz M, Falardeau E. Surveillance of laboratory exposures to human pathogens and toxins: Canada 2018. *Can Commun Dis Rep*. 2019 Sep 5;45(9):244-51. doi: 10.14745/ccdr.v45i09a04
6. Sejvar JJ, Johnson D, Popovic T, Miller JM, Downes F, Somsel P, et al. Assessing the risk of laboratory-acquired meningococcal disease *J Clin Microbiol*. 2005 Sep;43(9):4811-4. doi: 10.1128/JCM.43.9.4811-4814.2005
7. Barry M, Russi M, Armstrong L, Geller D, Tesh R, Dembry L, et al. Brief report: treatment of a laboratory-acquired Sabiá virus infection. *N Engl J Med*. 1995 Aug3;333(5):294-6. doi: 10.1056/NEJM199508033330505
8. Bouza E, Sanchez-Carrillo C, Hernangomez S, Gonzalez MJ. Laboratory-acquired brucellosis: a Spanish national survey. *J Hosp Infect*. 2005 Sep;61(1):80-3. doi: 10.1016/j.jhin.2005.02.018
9. Ergonul O, Celikbaş A, Tezeren D, Guvener E, Dokuzoğuz B. Analysis of risk factors for laboratory-acquired brucella infections. *J Hosp Infect*. 2004 Mar;56(3):223-7. doi: 10.1016/j.jhin.2003.12.020
10. Hsu CH, Farland J, Winters T, Gunn J, Caron D, Evans J. Laboratory-acquired vaccinia virus infection in a recently immunized person--Massachusetts, 2013. *MMWR Morb Mortal Wkly Rep*. 2015 May 1;64(16):435-8.
11. Kortepeter MG, Martin JW, Rusnak JM, Cieslak TJ, Warfield KL, Anderson EL, et al. Managing potential laboratory exposure to ebola virus by using a patient biocontainment care unit. *Emerg Infect Dis*. 2008 Jun;14(6):881-7. doi: 10.3201/eid1406.071489

12. Lim PL, Kurup A, Gopalakrishna G, Chan KP, Wong CW, Ng LC, et al. Laboratory-acquired severe acute respiratory syndrome. *N Engl J Med*. 2004 Apr 22;350(17):1740-5. doi: 10.1056/NEJMoa032565
13. International health regulations (2005). Third edition. Geneva: World Health Organization; 2016 (<https://apps.who.int/iris/bitstream/handle/10665/246107/9789241580496-eng.pdf?sequence=1>, accessed 6 December 2019).
14. Biosafety and biosecurity: standard for managing biological risk in the veterinary laboratory and animal facilities. In: Manual of diagnostic tests and vaccines for terrestrial animals, 8th edition. Paris: World Organisation for Animal Health (OIE); 2018 ([https://www.oie.int/fileadmin/Home/eng/Health\\_standards/tahm/1.01.04\\_BIOSAFETY\\_BIOSECURITY.pdf](https://www.oie.int/fileadmin/Home/eng/Health_standards/tahm/1.01.04_BIOSAFETY_BIOSECURITY.pdf), accessed 6 December 2019).
15. Biorisk management. Laboratory biosafety Guidance. Geneva: World Health Organization; 2006 ([https://www.who.int/csr/resources/publications/biosafety/WHO\\_CDS\\_EPR\\_2006\\_6.pdf](https://www.who.int/csr/resources/publications/biosafety/WHO_CDS_EPR_2006_6.pdf), accessed 6 December 2019).
16. WHO Global Plan of Action on Workers' Health (2008-2017): Baseline for Implementation. Geneva: World Health Organization; 2007 ([https://www.who.int/occupational\\_health/who\\_workers\\_health\\_web.pdf](https://www.who.int/occupational_health/who_workers_health_web.pdf), accessed 6 December 2019).
17. Biosafety programme management. Geneva: World Health Organization; 2020 (Laboratory biosafety manual, fourth edition and associated monographs)
18. Risk assessment. Geneva: World Health Organization; 2020 (Laboratory biosafety manual, fourth edition and associated monographs).
19. Biological safety cabinets and other primary containment devices. Geneva: World Health Organization; 2020 (Laboratory biosafety manual, fourth edition and associated monographs).
20. Personal protective equipment. Geneva: World Health Organization; 2020 (Laboratory biosafety manual, fourth edition and associated monographs).
21. Laboratory design and maintenance. Geneva: World Health Organization; 2020 (Laboratory biosafety manual, fourth edition and associated monographs).
22. Decontamination and waste management. Geneva: World Health Organization; 2020 (Laboratory biosafety manual, fourth edition and associated monographs).
23. Outbreak preparedness and resilience. Geneva: World Health Organization; 2020 (Laboratory biosafety manual, fourth edition and associated monographs).

24. The International Federation of Biosafety Associations Laboratory biosafety and biosecurity risk assessment technical guidance document. Albuquerque: Sandia National Laboratories; 2014 (<https://prod-ng.sandia.gov/techlib-noauth/access-control.cgi/2014/1415939r.pdf>, accessed 6 December 2019).
25. Responsible life sciences research for global health security. Geneva: World Health Organization; 2010 ([https://apps.who.int/iris/bitstream/handle/10665/70507/WHO\\_HSE\\_GAR\\_BDP\\_2010.2\\_eng.pdf?sequence=1](https://apps.who.int/iris/bitstream/handle/10665/70507/WHO_HSE_GAR_BDP_2010.2_eng.pdf?sequence=1), accessed 6 December 2019).
26. Renn O. White Paper on risk governance: toward an integrative framework. In: Renn O, Walker KD, editors. Global risk governance. Dordrecht: International Risk Governance Council; 2008. doi:10.1007/978-1-4020-6799-0\_1.
27. Laboratory safety guidance. Washington, DC: Occupational Safety and Health Administration, US Department of Labor; 2011 (<https://www.osha.gov/Publications/laboratory/OSHA3404laboratory-safety-guidance.pdf>, accessed 6 December 2019).
28. Pedrosa BS, Cardoso, TA. Viral infections in workers in hospital and research laboratory settings: a comparative review of infection modes and respective biosafety aspects. *Int J Infect Dis*. 2011 Jun;15(6):e366-76. doi: 10.1016/j.ijid.2011.03.005
29. Siengsanon-Lamont J, Blacksell SD. A review of laboratory-acquired infections in the asia-pacific: understanding risk and the need for improved biosafety for veterinary and zoonotic diseases. *Trop Med Infect Dis*. 2018 Mar 26;3(2):36. doi: 10.3390/tropicalmed3020036
30. Kimman TG, Smit E, Klein, MR. Evidence-based biosafety: a review of the principles and effectiveness of microbiological containment measures. *Clin Microbiol Rev*. 2008 Jul;21(3):403-25. doi: 10.1128/CMR.00014-08
31. Baldwin CL, Runkle RS. Biohazards symbol: development of a biological hazards warning signal. *Science*. 1967 Oct 13;158(3798):264-5. doi: 10.1126/science.158.3798.264
32. United Nations. Recommendations on the transport of dangerous goods: model regulations, 21st revised edition. New York, Geneva: United Nations; 2019 ([https://www.unece.org/trans/danger/publi/unrec/rev21/21files\\_e.html](https://www.unece.org/trans/danger/publi/unrec/rev21/21files_e.html), accessed 13 November 2020).
33. Technical instructions for the safe transport of dangerous goods by air (Doc 9284), 2017-2018 edition. Montreal: International Civil Aviation Organization; 2017 (<https://www.icao.int/safety/DangerousGoods/AddendumCorrigendum%20to%20the%20Technical%20Instructions/Doc%209284-2017-2018.AddendumNo2.en.pdf>, accessed 6 December 2019).

34. Infectious substances shipping guidelines, 15th edition (2019/2020). Montreal, International Air Transport Association; 2019
35. IMDG code. International maritime dangerous goods code: incorporating amendment 39-18. 2018 edition. London: International Maritime Organization; 2018 (<http://www.imo.org/en/Publications/IMDGCode/Pages/Default.aspx>, accessed 6 December 2019).
36. ADR, applicable as from 1 January 2019. European agreement concerning the international carriage of dangerous goods by road, Volumes I and II. New York and Geneva: United Nations; 2019. (<http://www.unece.org/trans/danger/publi/adr/adr2019/19contentse.html>, accessed 6 December 2019).
37. Regulation concerning the international carriage of dangerous goods by rail (RID). Berne: Intergovernmental Organisation for International Carriage by Rail; 2019. ([https://otif.org/en/?page\\_id=1105](https://otif.org/en/?page_id=1105), accessed 6 December 2019).
38. Nagoya protocol on access to genetic resources and the fair and equitable sharing of benefits arising from their utilization to the convention on biological diversity. Montreal: Secretariat of the Convention on Biological Diversity; 2014 (<https://www.cbd.int/abs/doc/protocol/nagoya-protocol-en.pdf>, accessed 6 December 2019).
39. Guidance on regulations for the transport of infectious substances 2019-2020. Geneva: World Health Organization; 2019 (WHO/WHE/CPI/2019.20) (<https://apps.who.int/iris/bitstream/handle/10665/325884/WHO-WHE-CPI-2019.20-eng.pdf?ua=1>, accessed 6 December 2019).
40. Biorisk management. Laboratory biosecurity guidance. Geneva: World Health Organization; 2006 ([https://www.who.int/csr/resources/publications/biosafety/WHO\\_CDS\\_EPR\\_2006\\_6.pdf](https://www.who.int/csr/resources/publications/biosafety/WHO_CDS_EPR_2006_6.pdf), accessed 6 December 2019).
41. WHO guidance on implementing regulatory requirements for biosafety and biosecurity in biomedical laboratories – a stepwise approach. Geneva: World Health Organization; 2020 (<https://apps.who.int/iris/bitstream/handle/10665/332244/9789241516266-eng.pdf?sequence=1&isAllowed=y>, accessed 15 June 2020)
42. An analytical approach: biosafety and biosecurity oversight framework [e-learning course]. Government of Canada; 2020 (<https://www.canada.ca/en/public-health/services/laboratory-biosafety-biosecurity/analytical-approach.html>, accessed 20 April 2020 [subscription required])
43. The Biological Weapons Convention. Convention on the Prohibition of the Development, Production and Stockpiling of Bacteriological (Biological) and Toxin Weapons and on their Destruction. United Nations; 1975 (<https://www.un.org/disarmament/wmd/bio/>, accessed 6 December 2019).

44. International Organization for Standardization (ISO) [website] (<https://www.iso.org/home.html>), accessed 6 December 2019).
45. Biosafety in microbiological and biomedical laboratories, 5th edition. Washington, DC: US Department of Health and Human Services; 2009 (<https://www.cdc.gov/labs/pdf/CDC-BiosafetyMicrobiologicalBiomedicalLaboratories-2009-P.PDF>), accessed 6 December 2019).

## Further information

Biological safety cabinet (BSC) 1: Introduction [Biosafety video series]. Geneva: World Health Organization; 2019 (<https://youtu.be/KHCT9OJqxPo>, accessed 6 December 2019).

Biological safety cabinet (BSC) 2: Preparatory steps [Biosafety video series]. Geneva: World Health Organization; 2019 (<https://youtu.be/4DoHJS8jL4U>, accessed 6 December 2019).

Biological safety cabinet (BSC) 3: Best practices for safe usage [Biosafety video series]. Geneva: World Health Organization; 2019 (<https://www.youtube.com/watch?v=18QEJUA9XBs>, accessed 6 December 2019).

Biological safety cabinet (BSC) 4: Incident management [Biosafety video series]. Geneva: World Health Organization; 2019 ([https://www.youtube.com/watch?v=aS\\_TCZTCcsI](https://www.youtube.com/watch?v=aS_TCZTCcsI), accessed 6 December 2019).

Good microbiological practices and procedures (GMPP) 1: personal protective equipment (PPE) [Biosafety video series]. Geneva: World Health Organization; 2019 (<https://youtu.be/Cuw8fqhwDZA>, accessed 6 December 2019).

Good microbiological practices and procedures (GMPP) 2: pipettes [Biosafety video series]. Geneva: World Health Organization; 2019 (<https://youtu.be/-zeCl8ESrpU>, accessed 6 December 2019).

Good microbiological practices and procedures (GMPP) 3: sharps [Biosafety video series]. Geneva: World Health Organization; 2019 (<https://youtu.be/yqX8hhzX7xU>, accessed 6 December 2019).

Good microbiological practices and procedures (GMPP) 4: surface decontamination [Biosafety video series]. Geneva: World Health Organization; 2019 (<https://youtu.be/b0PtPEnNakc>, accessed 6 December 2019).

Good microbiological practices and procedures (GMPP) 5: autoclaves [Biosafety video series]. Geneva: World Health Organization; 2019 (<https://youtu.be/Yfc1yjEuuuE>, accessed 6 December 2019).

Good microbiological practices and procedures (GMPP) 6: workflow [Biosafety video series]. Geneva: World Health Organization; 2019 (<https://youtu.be/TeYA2KqIU5k>, accessed 6 December 2019).

Good microbiological practices and procedures (GMPP) 7: transport [Biosafety video series]. Geneva: World Health Organization; 2019 (<https://youtu.be/RC9QHf2wdX0>, accessed 6 December 2019).











World Health  
Organization

9789240011311

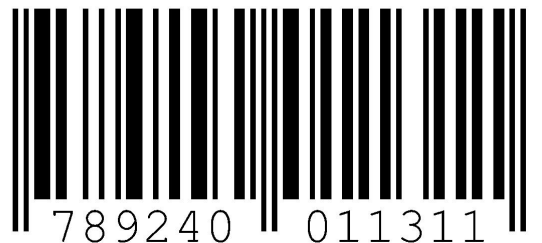

9 789240 011311